

SATELLITE ROUTER

EASTAR™

UHP-1000 SERIES



INSTALLATION AND OPERATION MANUAL

Document release 2.3

(for routers with SW version 2.2.9)

JANUARY 2010



ROMANTIS GmbH

WWW.ROMANTIS.COM

CONTENT

Acronyms and Abbreviations.....	5
introduction.....	7
Required level of qualification.....	7
Document version and applicability	7
Title.....	7
Compliance to Standards	7
1. general description	8
1.1 System overview	8
1.1.1 Purpose	8
1.1.2 Technical specifications	8
1.1.3 Router composition	9
1.1.4 Principles of operation.....	9
1.1.5 Measurement equipment, tools and accessories.....	13
1.1.6 Labeling and sealing	13
1.1.7 Packaging and content.....	14
1.2 Description and principles of operation	14
1.2.1 Overview.....	14
1.2.2 Power connector (DC IN)	15
1.2.3 LAN interface connector.....	15
1.2.4 USB CONSOLE	15
1.2.5 RESET button	15
1.2.6 High-speed demodulator IF input (SCPC RX)	15
1.2.7 Burst demodulator IF input (TDMA RX).....	16
1.2.8 Modulator output (TX OUT).....	16
1.2.9 “ERROR” Indicator	17
1.2.10 “STATUS” Indicator.....	17
1.2.11 “LOCK” Indicator	17
1.2.12 “TDMA” Indicator.....	17
1.2.13 “SCPC” Indicator	17
1.2.14 “TX” Indicator	17
2. Operations.....	18
2.1 Operational limits.....	18
2.2 Preparation for use	18
2.2.1 Unpacking.....	18
2.2.2 Installation.....	18
2.2.3 Connecting to external devices	19
2.2.4 Powering on.....	19
2.2.5 Local access to router via HTTP interface	20
2.2.6 HTTP interface.....	20
2.2.7 Local access via USB	21
2.2.8 Remote Telnet access	21

2.2.9	Command interface and command syntax	22
2.3	Interface management.....	22
2.4	Ethernet Interface	23
2.4.1	ARP Protocol	24
2.5	High-speed demodulator (SCPC Rx)	25
2.5.1	Receiving signals from satellite	25
2.5.2	Searching the satellite carrier	26
2.5.3	SCPC demodulator control commands	27
2.5.4	Additional commands.....	27
2.5.5	Standard sequence for operation with demodulator	29
2.6	Burst demodulator	30
2.7	Modulator	30
2.8	IP traffic processing and routing.....	32
2.8.1	SVLAN overview	32
2.8.2	IP-router.....	33
2.8.3	Router control commands	34
2.8.4	VLAN support.....	35
2.8.5	IP traffic screening	36
2.8.6	Prioritization and DSCP.....	37
2.8.7	Multicast routing.....	37
2.8.8	Compressing RTP packet headers.....	37
2.9	Traffic Shaper.....	38
2.10	Satellite Pointing.....	40
2.10.1	Pointing with HTTP assistance.....	41
2.10.2	Pointing via management console.....	41
2.10.3	Pointing with analog reference signal.....	42
2.10.4	Auto tracking signals during normal operations	43
2.11	Operations.....	43
2.11.1	Modes of operations.....	43
2.11.2	Switching between modes of operations	43
2.11.3	Exploitation	44
2.11.4	Troubleshooting	44
2.11.5	Configuration management	46
2.11.6	Events (LOGGING)	46
2.11.7	Limitations to access to the router.....	47
2.11.8	SNMP protocol.....	47
2.11.9	Additional commands.....	48
2.11.10	Controlling router status	48
2.11.11	Traffic diagnostics	48
2.11.12	Powering off.....	49
2.11.13	Safety instructions for operations	49
2.11.14	Actions in case of fire	49
3.	Exploitation.....	50
3.1	Technical maintenance.....	50

3.2	Router software	50
3.2.1	Software boot management	50
3.2.2	Software update	52
4.	Maintenance	53
4.1	Replacement of modules	53
4.1.1	Common recommendations	53
4.1.2	Safety instructions	53
4.2	Resetting to default settings	53
5.	STORAGE, TRANSPORTATION AND DISPOSAL	54

FIGURES

Figure 1	Satellite communication terrestrial station layout	10
Figure 2	Typical network diagram for SCPC dedicated channel	10
Figure 3	Typical network diagram for MCPC broadcasting	11
Figure 4	Typical TDM/TDMA network diagram	12
Figure 5	Typical Full Mesh network diagram	13
Figure 6	Standard labeling of satellite router	14
Figure 7	Packaging and content	14
Figure 8	UHP-1000 series modem – rear view	15
Figure 9	Radio equipment power supply control	15
Figure 10	UHP-1000 series modem front view	16
Figure 11	Example of router's connection in SCPC or TDM/TDMA terminal modes	19
Figure 12	Example of router's connection in TDM/TDMA Half Mesh mode	19
Figure 13	TDM/TDMA terminal installations page	20
Figure 14	Router statistics page	21
Figure 15	Graphical example of the entire signal path via satellite and antenna system	26
Figure 16	Satellite carrier search algorithm	26
Figure 17	Routing layout with examples of commands	33
Figure 18	IP traffic screening	36
Figure 19	Prioritization of traffic on the modulator	37
Figure 20	Principle of operation of Traffic Shaper	39
Figure 21	Example of Traffic Shaper operation	39
Figure 22	HTTP Information about the quality of signal reception	41
Figure 23	Pinout of USB Console interface	42
Figure 24	Router reboot procedure	51
Figure 25	Router resetting to default procedure	53

TABLES

Table 1	UHP-1000 Satellite Router Specifications	8
Table 2	Measurement results for receive base levels	9
Table 3	Operational limits	18
Table 4	TDM/TDMA Configuration Web page values	20
Table 5	Modulator parameters	30
Table 6	Troubleshooting guide	44

ACRONYMS AND ABBREVIATIONS

8PSK	Phase-shift keying (PSK) is a digital modulation scheme that conveys data by changing, or modulating, the phase of a reference signal (the carrier wave).
BCH	BCH code is a multilevel cyclic variable-length digital error-correcting code used for correcting multiple random error patterns. BCH codes may also be used with multilevel phase-shift keying whenever the number of levels is a prime number or a power of a prime number.
BUC	Block Up-Converter (BUC) is used in the transmission (uplink) of satellite signals. It converts a band (or "block") of frequencies from a lower frequency to a higher frequency.
C/N	Carrier-to-noise ratio, often written as CNR or C/N, is the signal-to-noise ratio (SNR) of a modulated signal.
CRTP	Compressing IP/UDP/RTP Headers for Low-Speed Serial Links
DSCP	Differentiated Services Code Point (DSCP) is a 6-bit field in the header of IP packets for packet classification purposes. DSCP replaces the outdated IP precedence, a 3-bit field in the Type of Service byte of the IP header originally used to classify and prioritize types of traffic
DVB	Digital Video Broadcasting (DVB) is a suite of internationally accepted open standards for digital television.
Eb/No	Eb/NO (the energy per bit to noise power spectral density ratio) is an important parameter in digital communication or data transmission. It is a normalized signal-to-noise ratio (SNR) measure, also known as the "SNR per bit". It is especially useful when comparing the bit error rate (BER) performance of different digital modulation schemes without taking bandwidth into account.
EIRP	Effective Isotropically Radiated Power
ETSI	The European Telecommunications Standards Institute (ETSI) is an independent, non-profit, standardization organization in the telecommunications industry (equipment makers and network operators) in Europe, with worldwide projection.
FEC	In telecommunication and information theory, forward error correction (FEC) is a system of error control for data transmission, whereby the sender adds redundant data to its messages, also known as an error-correction code.
HTTP	Hypertext Transfer Protocol (HTTP) is an application-level protocol for distributed, collaborative, hypermedia information systems.
HUB	Central Station of satellite network that is managing all the terminals and resources
HW	Hardware
ICMP	The Internet Control Message Protocol (ICMP) is used by networked devices to send error messages—indicating, for instance, that a requested service is not available or that a host or router could not be reached.
IESS	Intelsat Earth Station Standards
IP	IP is the usual abbreviation for Internet Protocol.
LDPC	Low-density parity-check (LDPC) code is a linear error correcting code, a method of transmitting a message over a noisy transmission channel, and is constructed using a sparse bipartite graph.
LNB	Low-noise block converter is the receiving converter installed at satellite antenna.
MCPC	Multiple Channels per Carrier
NMS	Network Management System
Node Station	Terminal of satellite network which is able to receive information directly from other network terminals
ODU	Out-Door Unit
QPSK	Phase-shift keying (PSK) is a digital modulation scheme that conveys data by changing, or modulating, the phase of a reference signal (the carrier wave).

RSV	Reed–Solomon error correction is an error-correcting code that works by oversampling a polynomial constructed from the data.
SCPC	Single Channel Per Carrier
SNMP	Simple Network Management Protocol
SNR	Signal-to-noise ratio is an electrical engineering measurement defined as the ratio of a signal power to the noise power corrupting the signal.
SR	Symbol Rate
SW	Software
TDM	Time Division Multiplexing
TDMA	Time Division Multiple Access
Telnet	Telecommunication Network (Telnet) is a network protocol used on the Internet or local area networks to provide a bidirectional interactive communications facility. Typically, telnet provides access to a command-line interface on a remote host via a virtual terminal connection.
Terminal	Earth Stations (usually VSAT) operated under management of network HUB
TFTP	Trivial File Transfer Protocol (TFTP) is a file transfer protocol, with the functionality of a very basic form of File Transfer Protocol (FTP).
UDP	The User Datagram Protocol (UDP) is the set of network protocols used for the Internet. With UDP, computer applications can send messages, in this case referred to as datagram, to other hosts on an Internet Protocol (IP) network without requiring prior communications to set up special transmission channels or data paths.
USB	USB (Universal Serial Bus) is a specification to establish communication between devices and a host controller (usually personal computers).
VLAN	A virtual LAN, commonly known as a VLAN, is a group of hosts with a common set of requirements that communicate as if they were attached to the same broadcast domain, regardless of their physical location.
VoIP	Voice over Internet Protocol (VoIP) is a general term for a family of transmission technologies for delivery of voice communications over IP networks such as the Internet or other packet-switched networks.
VSAT	Very Small Aperture Terminal – satellite earth station with small-size antenna
X-modem	Simple file-transfer protocol

INTRODUCTION

This document presents a general description of the EASTAR (trade mark) UHP-1000 series satellite routers and is intended for familiarization with the system capabilities and specifications. This manual describes all the key modes of the router operations. Some of such modes of operations are described in the separate manuals – attachments to this document.

Required level of qualification

This manual is intended for engineering personnel operating the EASTAR™ -based satellite networks. The engineers have to have a basic radio engineering education, experience in administration of data networks.

Document version and applicability

EASTAR™ UHP-1000 Satellite router is a basic element of network architecture and can be used at any level of network hierarchy. The functionality of the router and its modes of operations are determined by the activated software features.

This document version is 2.3 and it's **applicable for all EASTAR™ UHP-1000 series satellite routers with SW release 2.2.9**. When ordering this document please specify its article: ESD.IOM1.EN2.3.

Title

The content of this document is the intellectual property of Romantis GmbH (referred to below as Romantis). Copying or quoting this description as a whole or of any part of it without Romantis written permission is prohibited.

Compliance to Standards

Romantis declares that all manufactured EASTAR™ UHP-1000 series satellite routers comply with international industrial standards and requirements, namely to:

- ETSI EN 301 428 – Earth stations and satellite communication systems.
- ETSI EN 301 489-1 & -12 - Electromagnetic compatibility and RF spectrum.
- EN 60 950-1 – Telecommunication devices safety.
- Requirements to satellite communication earth stations operating in the Eutelsat system (type approval).
- Requirements to satellite communication land stations operating in the Intelsat system (type approval, IESS-308)).

1. GENERAL DESCRIPTION

1.1 System overview

1.1.1 Purpose

EASTAR™ satellite routers are essentially a universal solution for geographically distributed VSAT-class satellite communication networks. EASTAR™ routers can be used to organize simple point-to-point channels, "star"- and "mesh"-topology networks with several hierarchy levels and bandwidth-on-demand capabilities.

EASTAR™ VSAT platform is based on many innovation technologies. It was developed using long-term experience in satellite service provisioning. Nowadays electronics achievements made it possible to make VSAT platform compact and assure its efficiency and reach functionality.

1.1.2 Technical specifications

Table 1 UHP-1000 Satellite Router Specifications

PARAMETER	SPECIFICATION
MODULATOR	
Operation mode	Continuous (SCPC, MCPC) or burst (TDMA)
Transmission datarate	Up to 54 Mbps @ 1 Kbps steps
Modulation	QPSK, 8PSK (option)
Forward Error Coding	FEC 1/2 , 2/3, 3/4, 5/6, 7/8; RSV / LDPC&BCH / LDPC
Output spectrum	In compliance with IESS-308
Auto adjustment	Power Level, FEC ACM (option)
HIGH-SPEED DEMODULATOR	
Operation mode	Continuous (SCPC, MCPC)
Receive datarate	Up to 54 Mbit/s @ 1 Kbit/s steps
Modulation	QPSK, 8PSK (option)
Forward Error Coding	FEC 1/2 , 2/3, 3/4, 5/6, 7/8; RSV / LDPC&BCH (option)
BURST DEMODULATOR	
Operation mode	Burst (TDMA)
Receive datarate	Up to 6 Mbps (LDPC) @ 1 Kbit/s steps
Modulation	QPSK, 8PSK (option)
Forward Error Coding	FEC 2/3, 5/6 LDPC
INTERFACES	
LAN (User Interface)	Ethernet 10/100Base-T, RJ-45
Control console	USB
IF reception (SCPC Rx and TDMA Rx)	950-2050 MHz LNB converter power supply 13.5 VDC / 18 V (0.75A) Reference frequency 10 MHz / +5 dBm (TDMA Rx)
IF transmission (Tx OUT)	950 -1550 MHz ¹ Output power -35... -5 dBm ² @ with 0.1 dBm steps Reference frequency 10 MHz / +5 dBm Transmitter power supply 24 VDC (2A), with power-off capability
ROUTER	
Routing	Static routing and route announcement (RIP2 protocol)

¹ Up to 1700 MHz with no guaranty

² Up to -1 dBm with no guaranty

Table 1 UHP-1000 Satellite Router Specifications

PARAMETER	SPECIFICATION
IP-address support on the device	Up to 1000
Efficiency	96 Mbps (limited by LAN) or 28,000 pps Up to 1000 routes in the Table without losses in routing efficiency
Support	IP Multicast / DSCP / VLAN (+port tagging) / CRTP / L2 Bridge
Prioritization levels	3, adaptive
Control and monitoring	WWW, Telnet, SNMP-V2C
SW upgrade	TFTP, X-modem (3 banks for various versions)
HUB MODE TDM/TDMA	
Network size	Up to 252 terminals per each return channel (Inroute) up to 31 Inroutes per Network
Topologies	Point-to-point, Point-to-multipoint, Half Mesh, Full Mesh
ENVIRONMENT (IDU)	
Supply voltage	~ 100-240 VAC or 24 VDC
Power consumption, W	11, up to 80W with RF (Outdoor) equipment
Temperature range	0...+40 ⁰ C
Maximum humidity	Up to 90% @ 25 ⁰ C
Overall dimensions, mm	145 x 30 x 155 (router); 165 x 75 x 45 (power supply unit)
Brutto weight, kg, max	0,53 (router); 0,85 (power supply unit)

Table 2 Measurement results for receive base levels

FEC	C/N+N (Sp. An.)	C/N	Eb/No (data)	QPSK BER
1/2	5.0	3.4	3.7	9.0E-2
2/3	6.1	4.9	4.0	5.4E-2
3/4	7.0	6.0	4.6	3.5E-2
5/6	7.8	7.0	5.1	2.1E-2
7/8	8.5	7.8	5.8	1.3E-2

1.1.3 Router composition

UHP-1000 router consists of:

1. High-speed SCPC/MCPC demodulator
2. Burst demodulator
3. Universal modulator
4. Router
5. Controller
6. PSU - Power supply

PSU is an external device and provides a satellite router with power of 24VDC. UHP-1000 satellite router can be powered from any external DC power circuit with 24VDC and sufficient current.

1.1.4 Principles of operation

UHP-1000 Satellite Router is an in-door part of Satellite Earth Station. The outdoor part of the Earth station consists of:

- Satellite antenna;
- Block Up-Converter (BUC);
- Low-noise converter (LNB);

- Pair of coaxial cables connecting Outdoor and Indoor units.

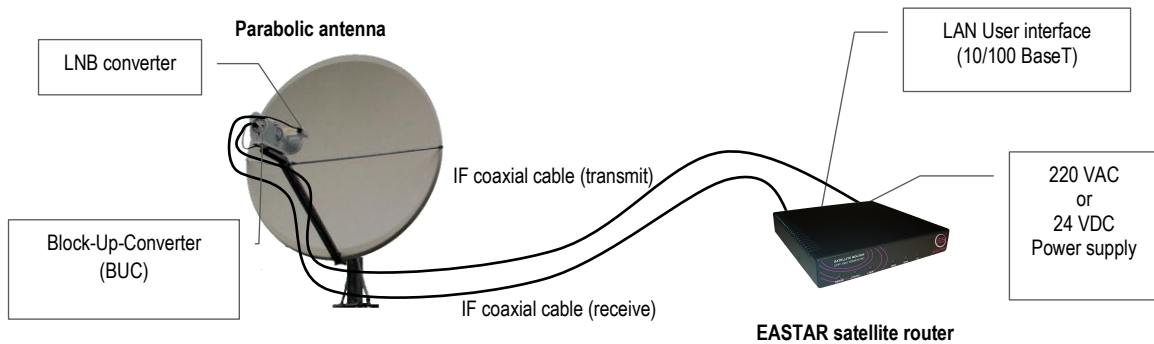

Figure 1 Satellite communication terrestrial station layout

HUB and Terminal layout is similar and can differ in the size of the antennas and RF equipment used, as well as by the satellite router type.

UHP-1000 routers can operate in the different modes depending on activated mode of operations:

- **SCPC** – a dedicated channel mode when Terminals interact with each other or with a HUB via fixed dedicated satellite bandwidth with a guaranteed physical level capacity (see Figure 2). Each terminal transmits one dedicated channel that will be received by opposite terminal. This mode is appropriate for channels with high capacity and steady high traffic. Hub is not required in this mode.

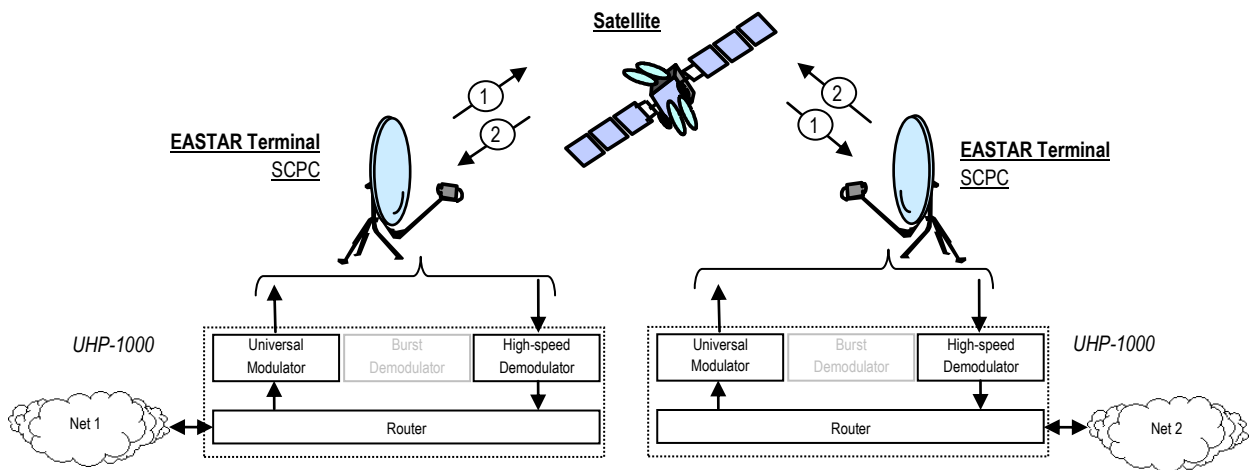

Figure 2 Typical network diagram for SCPC dedicated channel.

- **Broadcasting network** with dedicated MCPC channel. There two types of Earth Stations in such networks:
 - Uplink station that is continuously broadcasting MCPC carrier that containing information for a specific network station or for a group of such stations. When necessary Uplink station may control the quality of its transmission by receiving its carrier back from the satellite.
 - Unlimited number of stations that are receiving the carrier from the satellite and route any traffic intended for this destination to its LAN port. Such stations are, normally, receive-only without any transmission path.

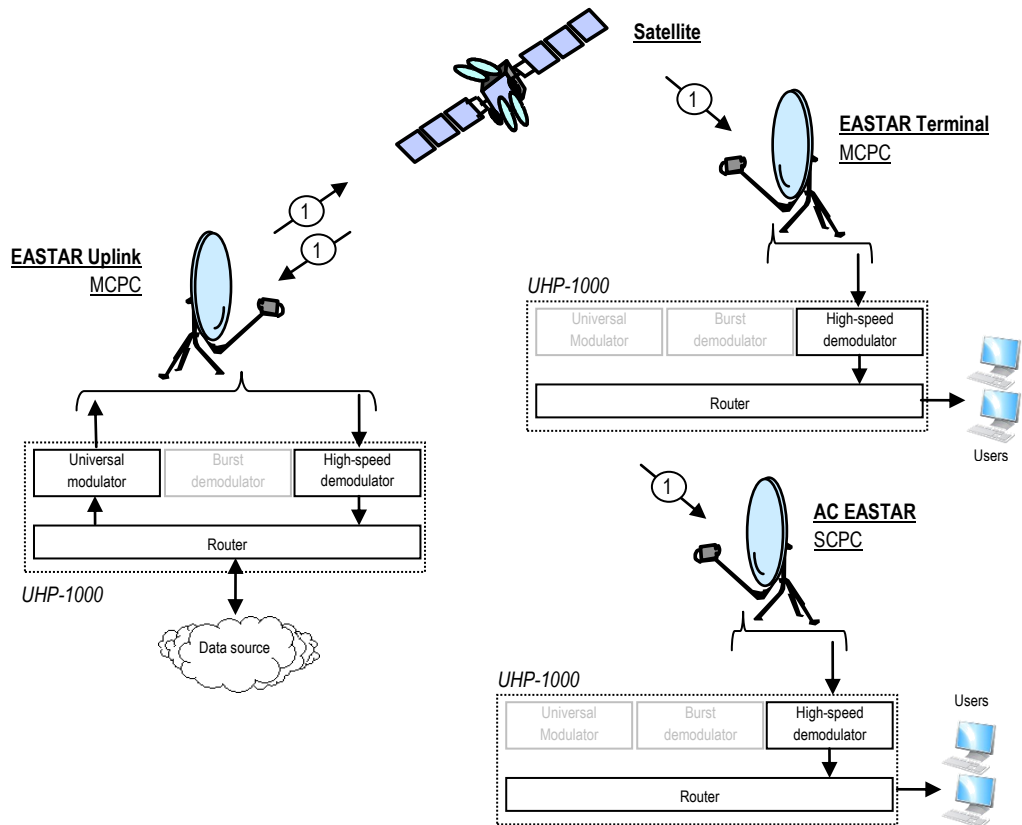

Figure 3 Typical network diagram for MCPC broadcasting.

- **TDM/TDMA network** – a network mode with dynamic redistribution of satellite network capacity consisting of Hub and Terminals. The TDM/TDMA network consists of:
 - Hub is a central station of the network that is managing operations of all Network Terminals and distributing the bandwidth accordingly to actual traffic load and predefined QoS. Hub is also acting as a gateway, concentrating and routing traffic of all Network Terminals to/from external networks. Hub consists of one or several UHP-1000 routers depending on network size. (See Figure 4)
 Hub constantly broadcasts common MCPC carrier - Outroute (1) dedicated to all network Terminals. Hub uses Time Division Multiplexing (TDM) to deliver data to specific terminal or to some group of terminals. Such data consists of user traffic and network management commands.
 Hub receives its Outroute channel from the satellite for calculation of the Time To Satellite (TTS) delay that is required for network synchronization.
 - Terminal - is network access equipment that interacts with the Hub in Hub/Spoke (Star) topology. Terminals receive the MCPC Outroute (1) broadcasted from the Hub and respond to the Hub via Time Divided Multiple Access (TDMA) carrier - Inroute (2). One or several TDMA Inroutes are shared between groups of Terminals. Each Terminal transmits its information as packets (burst) to individually-assigned time-slot determined by the Hub.
 - Mesh Terminal – an advanced mode of operation of basic Terminal that allows simultaneously receiving information from the Hub and other remotes. Mesh Terminal is also based on UHP-1000 router, but with enabled burst demodulator (which is software activated option of any UHP-1000 router). In such advanced mode Terminals may exchange

information in-between each other in one-satellite hop without any transit via Hub. Mesh Terminals allow creating network of any topology e.g. "tree", "star of stars", "Mesh", etc.

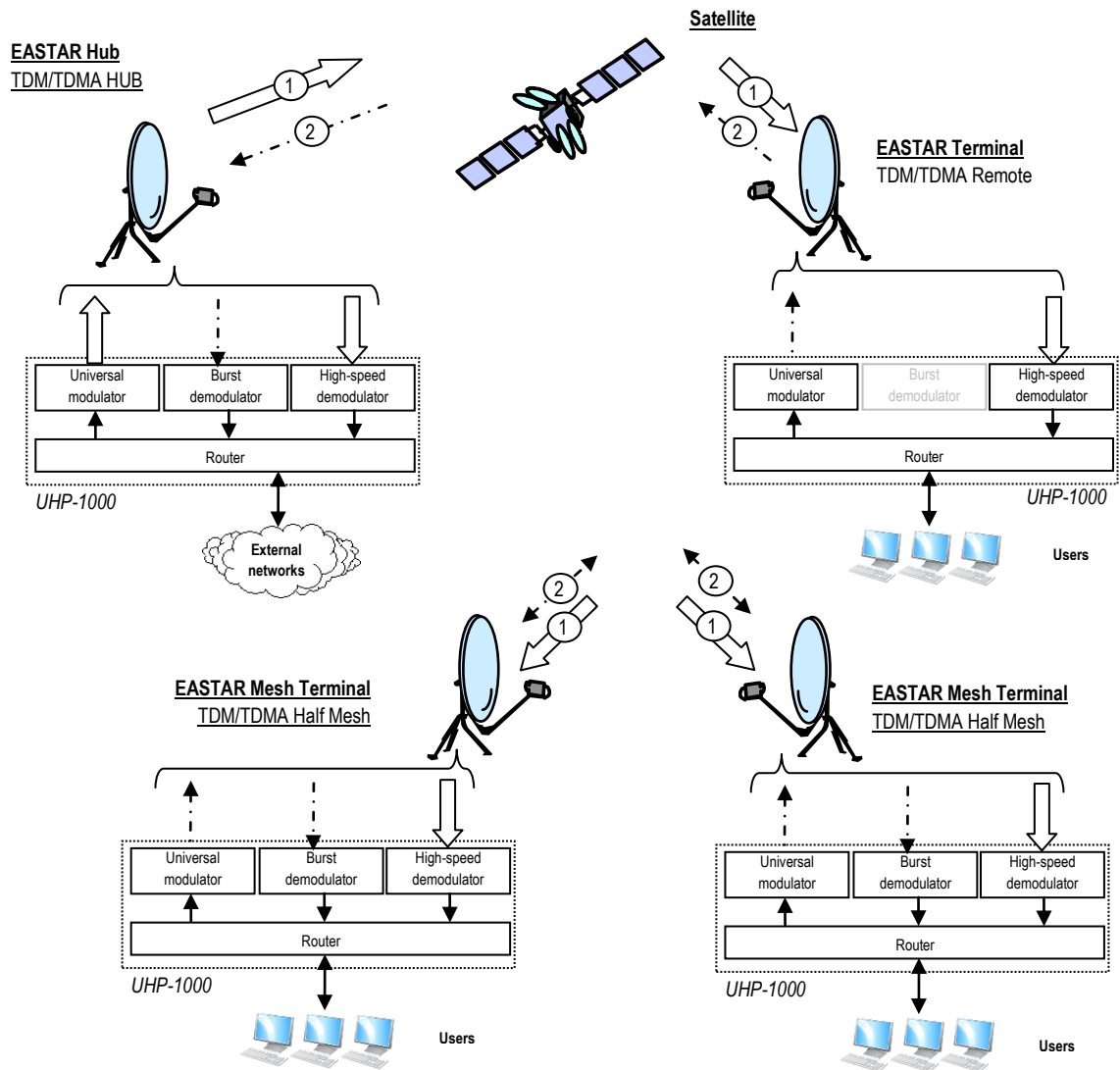

Figure 4 Typical TDM/TDMA network diagram.

- Full Mesh TDMA Network** (see Figure 5) consists of equal Earth Stations (Mesh Stations) that interact with each other through a common TDMA channel (1). This channel is used by all Mesh Stations to send and receive information with dynamic reallocation of the resource on demand. Theoretically, all network resources can be concentrated just for transmission or receive of one particular Network Station, if no other traffic in the network.

One of the Network Stations acts as a Master and takes over the functions of dynamic network resource allocation between other Stations. To ensure Full Mesh interactions between all the Stations a satellite link budget should be designed in such a way that all Stations properly receive each other. The minimum criterion is that all Network Stations properly receive the bursts of Master Station and vice versa. However, the network designed under such minimal criteria will behave as Star-topology system with a center at the Master Station.

High-speed demodulator in Full Mesh network is not in use and can be used to receive some additional traffic via MCPC carrier, such as broadband Internet. It could be a carrier from the same or from another satellite.

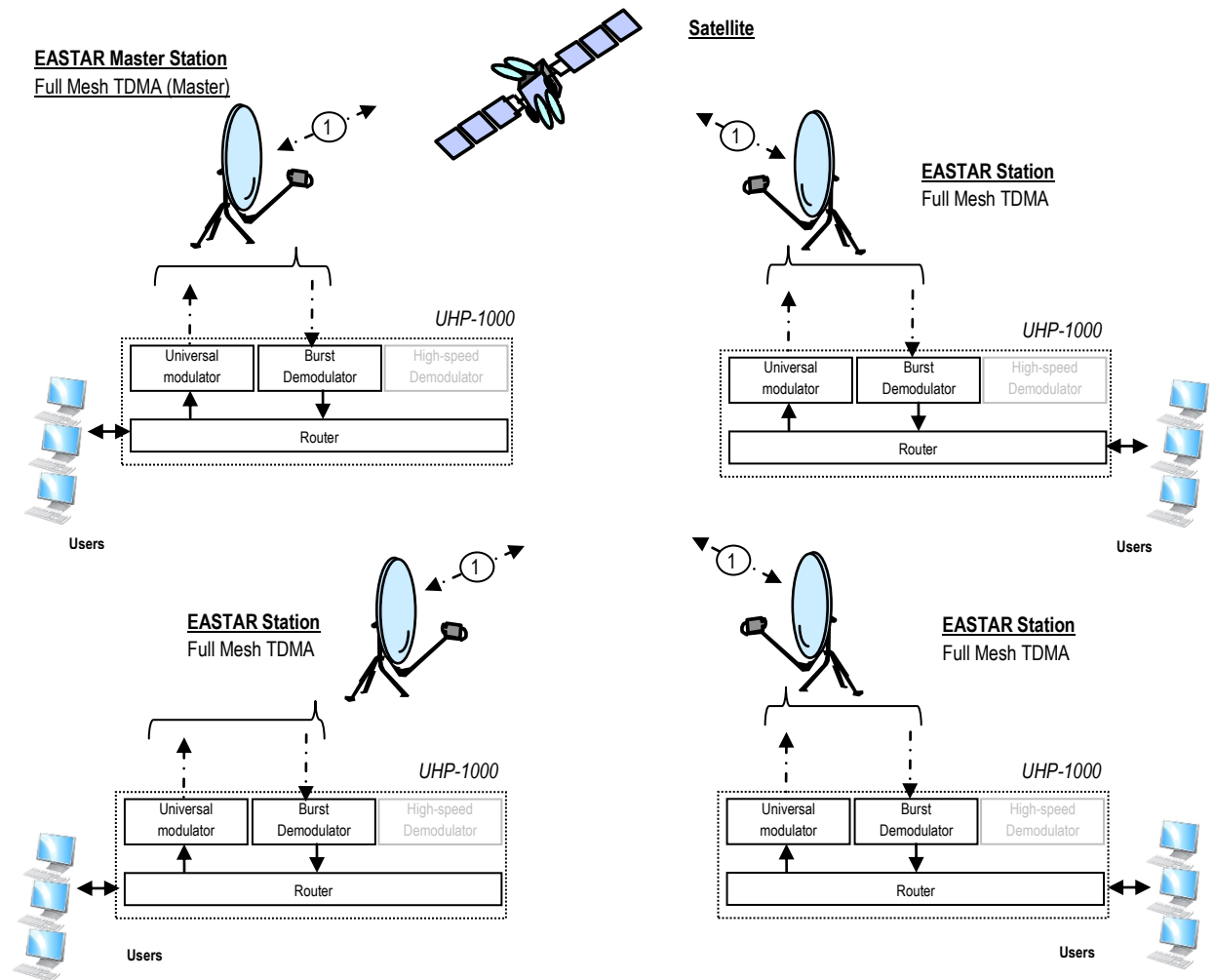

Figure 5 Typical Full Mesh network diagram.

1.1.5 Measurement equipment, tools and accessories

Standard computer (notebook) is required to configure and monitor status of EASTAR™ UHP-1000 satellite router. The computer must be equipped with a LAN interface and USB, and also have the following software installed:

- Internet browser (WEB browser)
- Telnet Client
- The Terminal (e.g.: Hyperterminal, included in the OS Windows) (optional)

The router can be accessed via LAN or USB ports. Standard USB AM/BM cable (not supplied) is required for connection to USB "Console" port of the satellite router.

Connection of a computer to the router via LAN interface is implemented through the Ethernet switch or hub via a standard network cable with RJ-45 connectors (not supplied).

1.1.6 Labeling and sealing

The product is marked with the unique Serial Number, as well as Part Number on the bottom of the router case.

The warranty seals are located on the bottom of the product, at the junction of the two parts of the case. Product warranty will automatically void if such labels have been removed, modified or damaged.

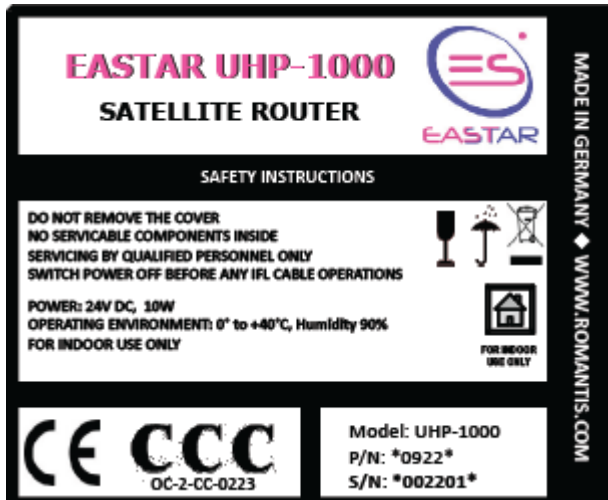

Figure 6 Standard labeling of satellite router

1.1.7 Packaging and content

Satellite router comes in a 355x205x55 mm box with gross weight 1,530 grams. It is recommended to keep original packaging throughout the entire lifetime. Conservation, storage and transportation of the terminal must be in original packaging.

Standard UHP-1000 package includes:

1. Satellite router UHP-1000
2. PSU
3. AC Power Cord
4. Documentation on CD-ROM
5. Stickers with description of the indicators



Figure 7 Packaging and content

1.2 Description and principles of operation

1.2.1 Overview

Each module of EASTAR™ UHP-1000 satellite router has its own interface to external devices. All the interfaces are located on the rear panel of the device. The indicators are located on the front panel. LAN Indicators are integrated into the LAN connector on the back of the router.



Figure 8 UHP-1000 series modem – rear view

1.2.2 Power connector (DC IN)

UHP-1000 router is powered with 24 VDC. AC Power supply adaptor is supplied with the set. The router can be powered from a DC power source (batteries, DC-DC converter), but the specific power supply mode should be agreed upon with the Manufacturer. Power supply connector features dimensions 5.5 / 2.1 mm (outer and inner diameters). Positive terminal of the source is on the central contact.

1.2.3 LAN interface connector

LAN connector is purposed for connecting to Ethernet switch using a straight cable. Bit rate 10 or 100 and duplex mode are software selectable. Indicators built into the connector mean the following: left one (green) – connection (Link) and data transmission (Activity), the right one –yellow) – activation of half-duplex mode.

1.2.4 USB CONSOLE

The console port provides local control of the device.

1.2.5 RESET button

Router reset is provided using this button. Also, using special combination of pressings this button allows router reset to factory settings.

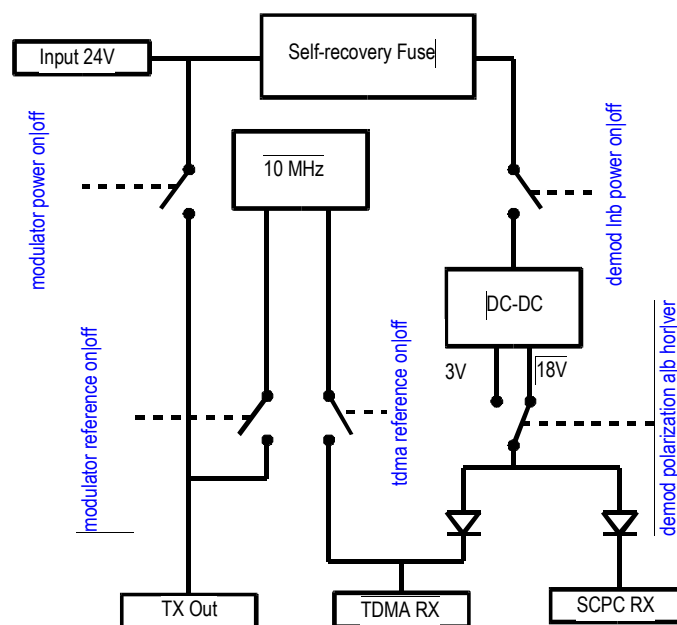

Figure 9 Radio equipment power supply control.

1.2.6 High-speed demodulator IF input (SCPC RX)

SCPC-RX is one of the two signal inputs to receive signals from the satellite (LNB). This input is designed to receive continuous (SCPC/MCPC) carriers in DVB-S and DVB-S2 formats from the satellite. The input, on the router side, can be fed with 13 or 18 V power supply.

Whether power source is on or off, the input can withstand external voltage up to 50 V (power supply circuit is provided with a diode). Short circuiting is not welcome since it creates high load on the device. Power supply circuit is protected with a thermal fuse operating in case of short circuiting. After short circuiting is removed it may be required to disconnect load from Rx inputs for several seconds so as to allow the fuse to return to its initial state.

Cable length and cable quality (losses level) can affect the quality and possibility of receiving signals.

1.2.7 Burst demodulator IF input (TDMA RX)

TDMA-RX is the second input for the signal from the satellite (LNB). This input is designed to receive bursts (TDMA) and continuous (SCPC/MCPC) carriers from the satellite in proprietary format. The input can also provide, from the router side, supply voltage 13 or 18 V, similar voltages being simultaneously fed to both inputs. The router can feed this input with a reference signal for using PLL LNB requiring external reference signal. When reference signal is switched off the router will not distort reference signal arriving at the input from outside. The rest conditions are similar to those across SCPC RX.

The total current consumed by external equipment through both RX inputs should not be in excess of 750 mA. Normally, current consumption by DRO LNB - 150 mA, PLL LNB - 500 mA.

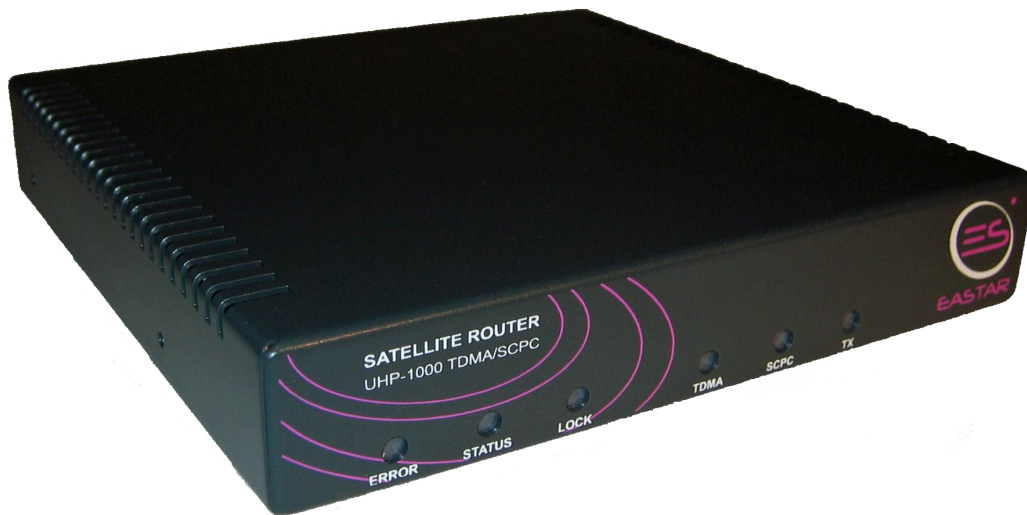

Figure 10 UHP-1000 series modem front view

1.2.8 Modulator output (TX OUT)

TX OUT output can feature 24 VDC with a high short-circuit current. Short circuiting can cause spark spread and burns. This voltage can damage measurement equipment if it is not protected at its inputs. Supplying external voltage to this connector is objectionable and supplying more than 24 V is prohibited.

UHP-1000 modulator is compatible with most satellite transmitters/converters (BUC). Those incompatible are only transmitters that require to explicit "TX On" FSK command but such transmitters are extremely rare and are not widely employed.

Modulator is connected directly to the transmitter IF connector. Router provides 24 VDC power supply to the transmitter and 10 MHz reference signal. UHP-1000 is not provided with a separate protection on the transmitter power supply circuitry. Use is made of current protection for the power supply adapter. In case of a short circuit the router is de-energized

and then gets restarted. If power supply is switched on in the configuration, restarts continue at 5 seconds interval until short circuiting is removed.

Any operations with IF TX cable should be performed with 24 V supply voltage turned off. Otherwise, self-induction across a long cable can damage the transmitter and/or router.

1.2.9 “ERROR” Indicator

“ERROR” red indicator makes it possible to infer about problems in the router functioning. The type of the generated problem can be judged by the number of indicator flashes:

1 – Demodulator cannot receive MCPC channel from the Hub (other Terminal). Please check AGC value in the demodulator statistics to determine whether there is a signal from antenna (see description of reception problems) to separate LNB and cable faults.

2 – Router cannot receive TDMA configuration from the HUB (TDM/TDMA network mode). The reason can be in the non-availability of receive channel from the HUB, CRC errors during reception, wrong configuration of the Terminal.

3 – Router cannot calculate time shift with respect to the HUB. The reason can be in the non-availability of reception or a large number of CRC errors during reception.

4 – HUB cannot receive signal from this terminal. Please check transmit signal level of the terminal, whether power supply and the reference signal for the transmitter are switched on (or off if required), whether DTTS is set correctly in the TDMA settings.

1.2.10 “STATUS” Indicator

“STATUS” green indicator indicates the router operation mode. This indicator is always flashing. If it does not flash it means that the router is not functioning (please check power supply). Slow flashing (once every second) means router normal operation. Faster flashing (3 times every second) means that a Telnet remote control session is established (in this case USB console does not operate until session is over).

Fast (6 times every second), simultaneous flashing of “ERROR” and “STATUS” indicators means that the router is functioning with the factory default configuration. Access to the router in this mode is possible either via USB or via IP-address 192.168.222.222 (mask 255.255.255.248 or /29).

1.2.11 “LOCK” Indicator

“LOCK” green indicator indicates whether the router receives a channel from the central station. If there are CRC errors during reception of information from the channel (e.g. with weak signal from the antenna), the indicator extinguishes for a fraction of a second at every error. If there are too many errors the indicator may not glow at all in spite of the fact that the router receives the channel (in this case please check the router demodulator statistics).

1.2.12 “TDMA” Indicator

“TDMA” yellow indicator flashes every time a data packet is received via TDMA RX interface.

1.2.13 “SCPC” Indicator

“SCPC” yellow indicator flashes every time a data packet is received via SCPC RX interface.

1.2.14 “TX” Indicator

“TX” yellow indicator flashes every time a data packet is transmitted in the MCPC mode, and also a blank packet – in the TDMA mode (if no data is available for transmission).

2. OPERATIONS

2.1 Operational limits

Table 3 Operational limits

#	Parameter	Limits	
		Minimum	Maximum
1	PSU Input voltage	100 VAC	240 VAC
2	Router DC Input voltage	23 VDC	25 VDC
3	Output current at Tx Out interface	-	2 A
4	Input voltage on the Tx Out interface	-	24 V
5	Output current at Rx SCPC or RX TDMA	-	0,75 A
6	Input voltage on other interfaces		18 V
7	Operational temperature	0 C	+40 °C
8	Relative humidity (@ 25°C)	0%	90%
9	Atmospheric pressure (mm Hg)	720	770
10	Mechanical impacts (acceleration with an amplitude not exceeding 1,25 mm): - in a range 0,5 – 15 Hz: - in a range 15-40 Hz: - in a range 40-300 Hz:		2,45 m/s 5,88 m/s 14,7 m/s

2.2 Preparation for use

2.2.1 Unpacking

Before opening the packaging please check a safety of transport container. If there is any visible damage of packaging you should keep it as long as the delivered equipment will be properly tested.

DO NOT OPEN THE PACKAGING BY ANY INSTRUMENTS WITH CUTTING EDGES EXCEEDING 2.5 CM. THIS MAY CAUSE DAMAGE TO HARDWARE OR CABLES.

Unpack the router in the following order:

1. Cut the tape on the front bottom of the cartons;
2. Extract from a cardboard box the router, power supply, power cord and a CD with documentation.
3. Store all packing materials for further storage or shipment of equipment.
4. Check equipment for the presence of any possible damage resulting from transportation.
5. Check the completeness of supply in accordance with the packing slip.

2.2.2 Installation

UHP-1000 Router is designed for installation on any flat, stable surface or on a shelf in the rack with the equipment or for installation in 5" bay of standard computer/server.

When installing in a rack or on a flat surface, make sure you have enough free space for ventilation of the power supply and the router (not less than 2 cm). When installing the router inside the computer or other systems we recommend using forced cooling to guarantee the normal thermal environment of the router.

2.2.3 Connecting to external devices

All wire connections must be performed before powering up the router. IF cable connectors should be screwed to the router without use of any mechanical instruments. Please, avoid excessive force when connecting IF cables.

WARNING! Do not connect or disconnect any connecting cables to the router with the power on. This can lead to a failure of the router and connected devices.

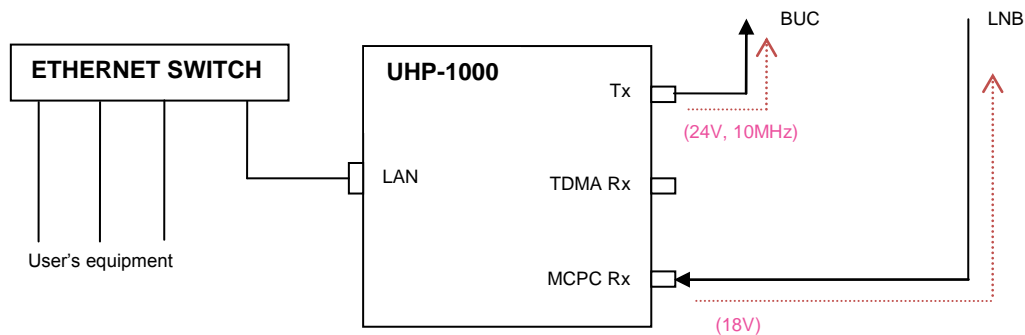

Figure 11 Example of router's connection in SCPC or TDM/TDMA terminal modes

Typically, the router UHP-1000 is connected to individual RF frequency equipment (ODU). In such configuration IF output of the modulator is connected to the power amplifier BUC, and the input of high-speed demodulator to LNB (Figure 11). The router will supply the BUC with 24V power and 10MHz reference signal. Also, the router may provide LNB with 18V DC power. The user's equipment should be connected to the router via Ethernet switch or hub, if you plan to connect only one device, it can be connected directly with Ethernet cross-over cable.

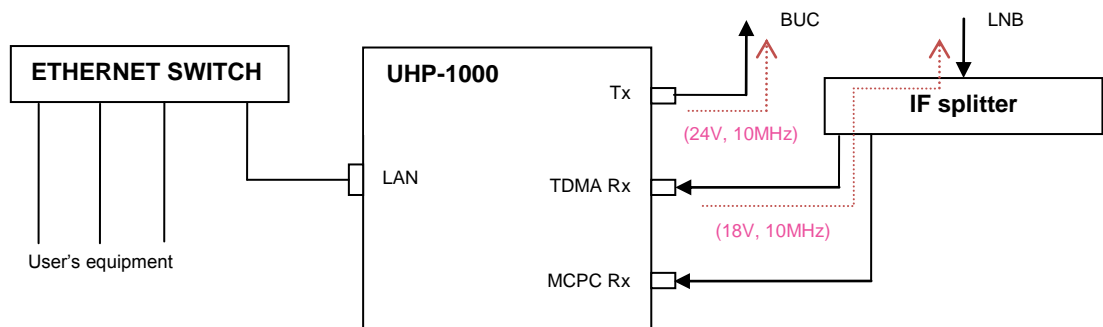

Figure 12 Example of router's connection in TDM/TDMA Half Mesh mode

In the Half Mesh mode the inputs of high-speed and burst demodulators should be connected to LNB via IF splitter (Figure 12). Such splitter has to ensure by-pass of DC for powering of the LNB and 10 MHz reference signal (required for PLL LNB normally used with Half Mesh terminals).

2.2.4 Powering on

In a few seconds after powering the router it is ready for use. Readiness of the router will be confirmed by "STATUS" LED indicator (blinking with a period of 1 second), as well as by single flashes of "ERROR" indicator, meaning a lack of reception of the receiving carrier.

With factory setting the router is configured as TDM/TDMA terminal. The router requires change of mode of operation (if necessary) and/or configuration of respective network parameters before login into satellite networks.

The easiest way to configure the router is using its HTTP access via its LAN port.

2.2.5 Local access to router via HTTP interface

HTTP (WWW) interface allows configuration key parameters and monitoring its actual status of the router. Local Web page of the router can be accessed from any Internet browser.

By default, UHP-1000 router is configured with IP-address 192.168.222.222 with mask 255.255.255.248 (/29). Respectively, the computer should be configured with an address, e.g. 192.168.222.217 with the same mask.

In case the satellite routers have been preconfigured at the factory on customer's request such routers may have different default IP address. In such case the respective IP addresses will be listed in the passport of the router. If it's impossible connecting the router with any of specified addressed please reset the router to factory settings (see Section **Ошибка! Источник ссылки не найден.**).

2.2.6 HTTP interface

HTTP (WWW) interface is intended for the initial configuration of the router to operate in a TDM/TDMA terminal mode (main mode of operation), as well as for monitoring key parameters in the process of satellite pointing and its further exploitation. Configuration of the router to work in other modes of operations is described hereafter and in respective Addendums to this Manual

Receive	TDMA	Transmit
LNB power: H-18V	Network (1-7): 1	TX 10M signal: <input checked="" type="checkbox"/>
Freq. (KHz): 1197220	Inroute (1-31): 1	TX 24V power: <input checked="" type="checkbox"/>
Symbol Rate: 2150	Station (1-252): 15	Transmit enable: <input checked="" type="checkbox"/>
<input checked="" type="radio"/> TDMA <input type="radio"/> CW <input type="text" value="1197220"/>	DTTS (us): -210	Level (1-360): 220
Apply		

Figure 13 TDM/TDMA terminal installations page

Parameters entered on this page, must be provided by Satellite Network administrator before installing the terminal.

Table 4 TDM/TDMA Configuration Web page values

Item	Value	Description
LNB power	Off / V-13V / H-18V	LNB powering modes
Freq. (KHz)	950 000-2 150 000	Outroute IF frequency in kHz (L-band)
Symbol Rate	250-39 000	Outroute Symbol Rate, ksps
TDMA	ON/OFF	Activation of normal TDMA transmission (Inroute)
CW	950 000-1 550 000	Frequency of unmodulated carrier (maintenance)
Network (1-7)	1-7	Network number
Inroute (1-31)	1-31	Number of return channel (Inroute)
Station (1-252)	1-252	Unique terminal ID
DTTS (us)	-10 000...10 000	Difference of time to satellite (acc to Hub), in us
TX 10M signal	ON/OFF	Activation of 10 MHz reference for BUC
TX 24V power	ON/OFF	BUC powering (24VDC) modes
Transmit enable	ON/OFF	Activation of transmission
Level (0-360)	0-360	Transmit power level

STATUS INSTALL POINTING SERVICE UHP VSAT Terminal Copyright Eastar Ltd. 2007	Refresh	Up-time: +01:21:41		Version: 2.2.10-9 (16.12.2009)		
	Interface	State	Info	TX speed (bps)	RX speed (bps)	RX CRC errors
	Demodulator	UP	Eb/N0=10.3dB	-	1113	107
	Modulator	UP	Lvl=-10.0dBm	0	-	-
	Ethernet	UP	Link=100/Full	0	0	0
	Serial	Disabled	-	-	-	-
	TDMA-Remote	Remote UP		Level_Off	Frq_Off	Cor_DTTS
	CurSlots=5	NrtReq=0, RtmReq=0		30	0	-4

Figure 14 Router statistics page

2.2.7 Local access via USB

When router is connected to a computer via a USB cable the computer creates a serial COM port. The port number can be found in the Device Manager. To access the port use can be made of either the OS-integrated terminal (Hyperterminal) or third-party terminal programs.

With the first connection of UHP-1000 Router to PC the system will request the device driver. UHP.INF driver is available on CD with documentation or can be downloaded from www.romantis.com. In response to the request for driver you should refuse from search in Internet and select setting from the specified place where UHP.INF is saved.

The system will request confirmation for using a non-certified driver. Ignore any system warnings and proceed with installation. When finished, please check whether a COM port appeared in the Device Manager. If it is appeared you can start working with the router.

When working with the port from the terminal program the data rate and control parameters can be set to any value since they are ignored.

WITH USB OC PROTOCOL STACK – THERE IS A PECULIARITY WHICH LEADS TO “HANGING” OF THE USB-PORT IF IT CARRIED AN ACTIVE SESSION AND THE CONNECTED DEVICE (ROUTER) AT THIS MOMENT WAS REBOOTED. IN THIS CASE YOU HAVE TO LOG OUT FROM THE TERMINAL PROGRAM AND LOG IN AGAIN. YOU CAN AVOID THIS BY CUTTING OFF THE SESSION BY “HANG-UP” COMMAND AND ONLY THEN RESTART THE ROUTER USING RESET BUTTON OR VIA POWER SUPPLY CIRCUIT.

2.2.8 Remote Telnet access

Remote access to the configuration can be performed using Telnet protocol. The connection can be provided to any of IP addresses that are set on the router. UHP-1000 supports simultaneously only one Telnet session. In order the hang session does not block access to the device forever in case on non-activity (pressing ENTER key), the router auto-terminates the session after a certain time of inactivity. The time can be set in the configuration, and by default it is 10 minutes.

There is one more (emergency) method to issue commands to the router remotely. One of the SNMP variables allows, after a text string is transmitted to the router using SNMP protocol, execution of this string as a command. The advantage of this method is that a reverse channel for transmission of commands is not a must – this can be useful to restore operation in emergency cases. Printout of command is not transmitted back as the SNMP response? So command execution is “blind”.

2.2.9 Command interface and command syntax

When opening a command session (Telnet or USB) the router can, depending on the configuration, request a password. If password is not set the commands can be entered immediately.

The system invitation starts with the router name (it is set using the relative command). Then enter «#» symbol in the administrator mode or «>» symbol in the user mode (user cannot change configuration).

Router commands include key words and parameters. **All key words can be reduced to two letters.** Letter case is unimportant. Wrong entered symbols can be edited by returning to them using Backspace key. "Left" and "right" arrows cannot be used for editing. "Up" arrow is used to recall commands used earlier.

Commands list can be printed using "help".

```
UHP# he
----- Interface control
interface ethernet|serial|demod|modulator disable|enable - IF Control
clear interface ethernet|serial|demod|mod - Reinitialize interface
----- Ethernet interface parameters
ethernet mode ehalf|efull|fhalf|ffull|auto - Speed and duplex selection
arp timeout 30-3600 - ARP table purge interval
----- Demodulator common parameters
demodulator lnb frequency 0-1400000 - LNB LO frequency (KHz)
demodulator lnb power off|on - LNB power control
demodulator search 0-200000 - Carrier search bandwidth (+/-KHz)
demodulator reference off|on - TDMA RX connector 10 MHz output
----- Demodulator profile parameters
demodulator profile a|b disable|enable - Enable/disable profile
demodulator polarization a|b vertical|horizontal - Polarization
demodulator frequency a|b 950000-2150000 - Central frequency (KHz)
```

Command syntax meaning:

- [] - optional parameter
- x|y - selection of one of the key words, e.g. "on" or "off"
- x-y - numerical value in the range from x to y inclusive
- STRING - symbols string
- IP_ADDR - IP address, e.g. 192.168.0.1
- IP_MASK - IP mask in classical or CIDR form (255.255.255.0 /24 /32)

ADDRESS AND MASK MUST BE SEPARATED BY BLANK SPACE – THESE ARE DIFFERENT PARAMETERS.

ML, MM, MH, MD- abbreviations for the name of the modulator transmission priority queues (Low, Medium, High, DSCP)

2.3 Interface management

Router interfaces feature the following designations in the commands set:

- Ethernet** - Ethernet LAN (LAN)
- Demodulator** - High speed demodulator (SCPC Rx)
- TDMA** - Packet demodulator (TDMA Rx)
- Modulator** - Modulator (Tx OUT)

Each interface is provided with a page showing parameter settings and operation statistics. The page is called using "show interface ..." command with the interface name. Each page starts with the following header:

```
UHP#sh in et
Ethernet interface is UP
Last U->D: never      U->D transitions:0
Last D->U: +00:00:04  Counters reset: 17.Oct 09:00:18
...
```

The first string shows the current state of the interface:

ADMINISTRATIVELY DISABLED - switched off by the user command
DOWN - switched on but not working (external conditions)
UP - switched on and working

The interface changes to UP if it is switched on and the following condition is adhered to:

Ethernet - connected to the switch (hub, computer)
TDMA - if signal is received from the satellite
Demodulator - if signal is received from the satellite
Modulator - if transmission is switched on

Then the accumulated statistics on changes in the interface state comes up.

Last U->D - time when the last transition from UP to DOWN occurred
Last D->U - time when the last transition from DOWN to UP occurred
U->D transitions - number of transitions to DOWN
Counters reset - time when the last cleaning of counters occurred

These counters are reset together with statistics counters on the relevant commands. Then information on the specific interfaces comes up.

Interface control commands:

```
show interface ethernet|tdma|demodulator|modulator - Interface stats
Print settings and statistics of the interface.
```

```
interface ethernet|tdma|demod|modulator enable|disable - IF Control
Switch interface on or off.
```

```
clear interface ethernet|tdma|demod|mod - Reinitialize interface
Perform hardware re-initialization of the interface. Using this command is not recommended.
```

```
clear counters all|ethernet|demod|modulator|ip|tdma - Reset stats
Clean interface counters. With the "IP" parameter the command cleans counters of the route Table.
```

2.4 Ethernet Interface

As for this interface, only mode of operation with the switch is set.

```
----- Ethernet interface parameters
ethernet mode ehalf|efull|fhalf|ffull|auto - Speed and duplex selection
You can select the rate and duplex mode. «e» in the parameter heading means 10 megabit, «f»- 100 megabit,
"half and full" control the duplex operation. Auto selects auto-negotiation of parameters (set by default).
```

Statistics can be seen using "show interface ethernet" command.

```
EASTAR # sh in et
Ethernet interface is UP
Last U->D: never          U->D transitions: 0
Last D->U: +00:00:04     Counters cleared: never
MAC: 46:13:44:89:16:98  Set: AUTO          State: 100/Full|TX queue | 0
|-----+----- RX -----+----- TX -----+-----+-----|No buffer| 0
|Rate | 1419          | 147          |Bcasts | 37          |Collision| 0
|Bytes| 2551          | 1510         |CRC errs| 0           |16 colls.| 0
|Pkts.| 37           | 31           |Overruns| 0           |Underruns| 0
```

```
MAC: 00:12:34:56:1B:45 Set: AUTO State: 10/HD |TX queue | 0
```

MAC - Interface physical address (set by Manufacturer)
 Set - Preset mode of communication between interface and the switch.
 State - Current mode of communication with the switch.
 TX - Queue length (in bytes) for transmission.

```
|-----+----- RX -----+----- TX -----+-----+-----|No buffer| 0
```

Two rows RX and TX in subsequent lines show statistics of reception and transmission.
 No buffer - Number of packets reset from the queue due to excessive interface traffic in transmit mode.

```
|Rate | 102          | 0          |Bcasts | 4127         |Collision| 0
```

Speed - Current traffic rate across interface.
 Bcasts - Number of received broadcast packets.
 Collision - Number of collisions in transmit half-duplex mode.

```
|Bytes| 315057        | 0          |CRC errs| 0           |16 colls.| 0
```

Bytes - Number of bytes (including Ethernet heading), that have passed through interface.
 CRC errs - Number of packet checksum errors in receive mode.
 16-colls - Number of multiple collisions. Means serious overload on the local network segment or problems with the switch.

```
|Pkts.| 4127          | 0          |Overruns| 0           |Underruns| 0
```

Pkts - Number of packets that have passed through interface.
 Overruns - Number of occasions when processor did not have enough time to process the received packet.
 Underruns - Number of occasions when processor did not have enough time to prepare data to send.

All counters can be reset using "clear counters ethernet" command.

2.4.1 ARP Protocol

ARP protocol assists devices on the Ethernet segment to communicate using IP-protocol. Addressing in Ethernet differs from IP-addressing and ARP makes it possible to obtain peer MAC addresses in compliance with their IP-addresses. The protocol is transparent for the user and does not require any configuration.

ARP Tables control commands:

```
arp timeout 30-3600 - ARP table purge interval
```

Sets interval (in seconds) between cleanups ARP Table. If IP-address is set on one device in the network and then the device is disconnected from it and the same address is set on another device, the devices may fail to communicate with this other device until their ARP Tables are cleaned and updated.

```
clear arp-table - Clean ARP Table.
show arp - Print current content of ARP Table:
```

Example:

```
UHP#sh arp
10.0.0.10 - 00:14:2A:7D:95:E9
10.0.0.11 - 00:12:34:56:2D:4E
10.0.0.12 - 00:12:34:56:53:55
```

An IP-address and its relevant MAC-address are shown on each line.

```
Free entries: 241      Purge interval 600
```

Free entries - Number of free cells in the Table.

Purge interval- Interval between Table updates.

```
ARP requests: 4      ARP answers: 0
```

ARP requests - Number of ARP requests generated by the router.

ARP answers - Number of router answers to ARP requests from the network.

2.5 High-speed demodulator (SCPC Rx)

Demodulator of the continuous signals is intended for reception of satellite channels transmitted by another UHP-1000 router or by a special modulator. On the physical level, transmission format complies with DVB-S and DVB-S2 standards but the channel level is incompatible with DVB – there is no PID conception, etc. Instead, use is made of the own encapsulation methods which are more efficient in transmitting IP-protocol.

2.5.1 Receiving signals from satellite

To receive signal (carrier) from satellite, it is essential to know at least four parameters:

- The satellite used in the network (antenna should be pointed to this satellite)
- Polarization (proper polarization should be selected on in the demodulator configuration or the receive converter on the antenna should be turned to the required position if its polarization cannot be switched over using its supply voltage)
- Carrier central frequency (enter its value in the demodulator configuration)
- Carrier symbol rate (enter the value in the demodulator configuration)

Satellite channel frequencies can be in three bands:

- Ku (10.7 – 12.5 GHz) – frequency at which satellite transmits the carrier
- C (4 – 5 GHz) – frequency at which satellite transmits the carrier
- L (950-2050 MHz) – frequency converted by the receive converter (LNB) and which is applied to the router's demodulator input

Reception of the signal is effected using receive converter (LNB). It performs two functions: amplification of the weak signals and converting them to similar signals carried at a much lower frequency (called intermediate frequency or IF). When converting the frequency, frequency of the local oscillator (LO) is subtracted from that of the signal received by LNB from the satellite. LO frequency of various LNBs can be 10 GHz (professional converters), 0.975 GHz and 10.7 GHz (domestic converters). LO frequency is usually written on the converter case label or in its Manual.

There are double-frequency (wideband) converters containing two LOs with different frequencies. These converters are switched over using frequency 22 KHz. UHP-1000 routers do not support 22 KHz control signals and cannot switch LO in such converters. If converter switches the LO using voltage of 13/18 V, the router will be capable of switching LO frequency.

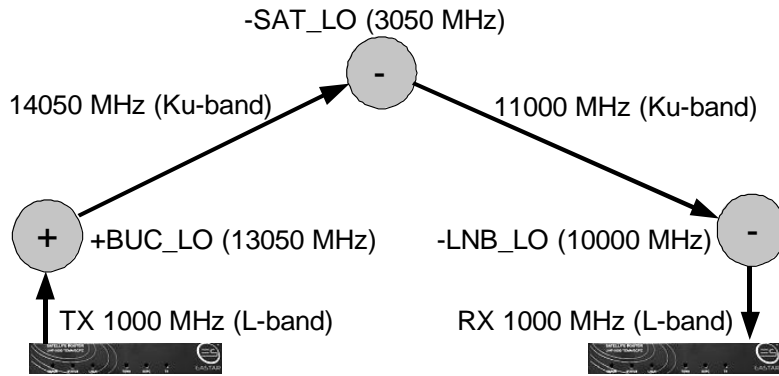

Figure 15 Graphical example of the entire signal path via satellite and antenna system

If the satellite signal frequency is known in Ku-band, e.g. 11 215 140 000 Hz (or 11.215140 GHz or 11 215 140 KHz), then knowing the LO frequency of the installed LNB (e.g. 9.75 GHz) one can calculate the value in the L-band.

$$11\ 215\ 140\ 000 - 9\ 750\ 000\ 000 = 1\ 465\ 140\ 000\ \text{Hz OR } 1\ 465\ 140\ \text{KHz}$$

2.5.2 Searching the satellite carrier

Any LNB features LO frequency deviation from its declared value. This deviation has a certain constant component plus component caused by temperature changes. Constant component may vary slowly due to LNB components aging. Deviation due to temperature (winter/summer) usually lies within the bandwidth of ± 500 KHz. Constant component is usually not in excess of 500 KHz to either side but there are samples with deviation of up to 1,500 KHz. PLL LNB with 10 MHz internal reference fall also under this effect but their deviation range is substantially lower – just a few KHz. Accuracy of PLL LNB with external reference frequency depends on the accuracy of the router reference oscillator.

The LO inaccuracy leads to the fact that the real frequency of the carrier coming to the router differs from that at which we expect this carrier.

Respectively, the router should search for the carrier in a certain bandwidth close to the selected value. The search algorithm is as follows:

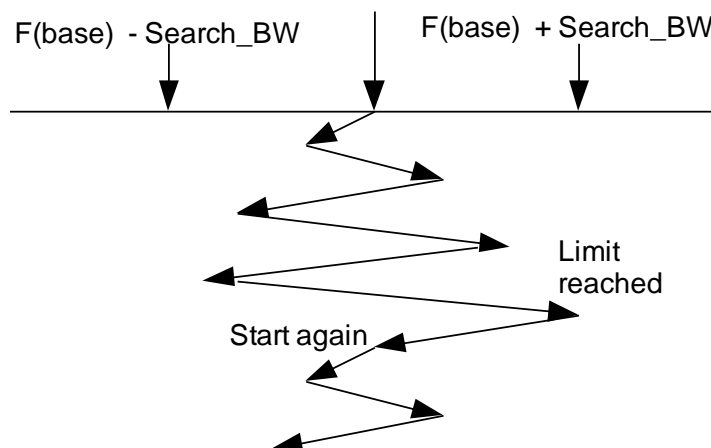

Figure 16 Satellite carrier search algorithm

Search is carried out within a certain user-defined bandwidth. If the carrier is not found upon reaching the search limit the search is repeated. Search bandwidth should be wider than the possible frequency offset caused by deviation in LO LNB. But the wider the range the longer is the complete search cycle.

2.5.3 SCPC demodulator control commands

Most commands of the demodulator come into force as the carrier search operation is initiated. If the search is already under way the values come into force immediately. The essence of this behavior is that if demodulator receives the carrier the user gets maximum possibilities to configure the demodulator without interrupting the reception. This is particularly actual for a remote configuration.

`demod lnb power on|off` - LNB power control

Switching LNB power supply on and off. Comes into force immediately.

`demod search 0-200000` - Carrier search bandwidth (+/-KHz)

Maximum deviation from the assigned frequency during carrier search. Full search bandwidth (to both sides) is equal to the double value. If the command is issued with the 0 value, the bandwidth does not change, and the LNB offset value is reset to 0.

`demod reference off|on` - TDMA RX connector 10 MHz output

Activation of 10 MHz reference signal on TDMA Rx input.

The router demodulator is provided with two sets of carrier settings referred to as profiles A and B. Both profiles are needed when there is a necessity to shift to a new carrier while working on the former and without deleting settings of the former (so as to be able to go back if necessary).

Demodulator strategy of operation is searching the carrier over all permitted profiles until it is found. When carrier is lost the search is resumed. Subsequent commands are designed to configure profile parameters. New parameters come into force during search operation.

`demod profile a|b enable|disable` - Enable/disable profile

Permits or prohibits profile operation.

`demod polarization a|b vertical|horizontal` - Polarization

Controls polarization by switching LNB supply voltage 13/18 V (if LNB power supply is allowed by the demod lnb power command).

`demod frequency a|b 950000-2150000` - Central frequency (KHz)

Carrier frequency in KHz.

`demod symbolrate a|b 100-34000` - Symbol rate (KSps)

Carrier symbol rate in kilosymbols per second. Recommended minimum demodulator symbol rate is not less 250 kbps. In some applications the demodulator may stable work with a lower symbol rate.

`demodulator mode a|b s1|s2` - DVB-S1 or DVB-S2 mode select

DVB-S1 or DVB-S2 demodulator operation mode.

`demod viterbi a|b 1/2|2/3|3/4|5/6|7/8|auto` - FEC: Viterbi

Type of correction code for DVB-S1 mode. With the auto parameter and in DVB-S2 mode the decoder is self-tuned.

`demod spectrum a|b on|off|auto` - Spectrum Inversion

Spectrum inversion during signal reception. The specifics of transmitters. If inversion is detected we recommend to switch it on the transmitting side to allow reception without inversion (a better way) or switch it on in receive mode using this command. This reduces carrier search time.

2.5.4 Additional commands

`demod activate a|b` - Activate carrier profile

Immediate initiation of search by the assigned profile. The command is usually used only for just made changes in the demodulator configuration in case the demodulator is already receiving any carrier. Initiation of search by the switched off profile is allowed. In this case the search is performed once. If the carrier is detected the demodulator will receive it. If the carrier is not detected the demodulator will switch over to another profile and will not return to the switched off profile afterwards.

demod compensate - Compensate LNB frequency offset

This command operates only when demodulator is receiving the carrier. Current carrier frequency offset determined by the demodulator is saved in the Offset special parameter and later is added to all frequencies during all search operations. This allows compensation of the LO LNB deviation constant part and speedup the search owing to the narrower search bandwidth. The command immediately restarts the carrier search with new parameters. Offset reset to 0 takes place during entering the demod search 0 command (the search bandwidth assigned earlier is NOT changed in this case).

demod bert qpsk|re|data - Bit error rate meter

Initiation of the bit error rate (BERT) analyzer on the demodulator. There are three BERT modes:

- QPSK - bit error rate in the signal coming from satellite (prior to correction)
- REED-Solomon - bit error rate that have not been corrected by Viterbi decoder
- DATA - bit error rate for data at the demodulator output

Example:

```
REMOTE#de be qp
```

```

                                QPSK BERT Q-quit
+00:00:03 Eb/No=7.2 (7.0<>7.2) BER_1s=8.0E-3 BER=8.0E-3 CRCs=0

```

- +HH:MM:SS - Duration of the test.
- Eb/No - Current signal-to-noise ratio in decibel.
- (...<>...) - Minimum and maximum signal-to-noise ratios during the test.
- BER_1sec - Bit error rate at this instant.
- BER - Average level during the test.

Demodulator settings and statistics of operation can be displayed using "show interface demodulator" command:

```
REMOTE#sh in de
```

```

Demodulator interface is UP
Last U->D: never U>D transitions:0
Last D->U: +00:00:03 Counters reset: never
----- Outdoor Unit -----
| LNB-pwr: ON T10M: ON Offset: 0 KHz Search BW: 2000 KHz |

```

- LNB power - LNB power supply on/off.
- T10M - 10MHz Reference signal on TDMA Rx input
- Offset - LNB frequency offset saved by the demod compensate command
- Search BW - Carrier search bandwidth.

Profile settings

```

----- Link profiles -----
| Pr| State | Frq.KHz | Polar.| SR.KSps | FEC | SpInv | Mode |
| A | RECEIVE | 1497220 | H 18V | 2105 | AUTO | AUTO | S1 |
| B | DISABLED | 1351000 | H 18V | 300 | AUTO | AUTO | S1 |

```

- Pr - Profile.
- State - Current state:
 - RECEIVE - Carrier is being received.
 - SEARCH - Carrier search under way.
 - STANDBY - Profile is on but at the moment another profile is working.
 - DISABLED - Profile is off.
- Frq.KHz - Central frequency.
- Polar. - LNB polarization and supply voltage (is permitted).
- SR.KSps - Symbol rate.
- FEC - Noiseless decoder mode.
- Spinv - Spectrum inversion mode.
- Mode - DVB-S1 or DVB-S2 demodulator mode.

Receive signal statistics in DVB-S mode

----- Demodulator state -----							
InLvl	SpI	FEC	RS	SRoff	RX_BER	Eb/NO	RX-offset
-58.7	OFF	3/4	LOCK	0	6.0E-3	7.2	-9 KHz

Current state of the demodulator receiver:

- InLvl - Common level of signal on the input. "NOSIG" for level <-85dBm
- SpInv - Spectrum inversion current mode.
- FEC - Viterbi decoder mode.
- RS - Carrier capture. LOCK means that the carries is detected.
- SR_off - Correction to the symbol rate (smb/sec). Not valid during search.
- RX_BER - BER in receive mode. Not valid during search.
- Eb/No - Signal-to-noise ratio in dB. Not valid during search.
- RX-offset - Carrier frequency offset from the assigned value including Offset parameter. Large offsets (up to 1000 KHz) do not affect reception quality but slow down search operation.

----- Data received -----			
Rate/bps: 0	Packets: 24394	Bytes: 493408	CRC_errors: 7612

- Rate/bps - Current traffic rate at the interface in bits per second.
- Packets - Number of received packets.
- Bytes - Number of received bytes.
- CRC_errors - Number of errors in received packets. There is a peculiarity that if the channel traffic load is not 100%, then some channel errors do not corrupt packet data and do not cause CRC errors.

To clean counters use is made of the "clear counters demodulator" command.

2.5.5 Standard sequence for operation with demodulator

When preparing to receive carrier for the first time after equipment installation:

- ▶ Connect cable to LNB.
- ▶ Switch on LNB power supply (de In po on) if LNB does not use any other power supply.
- ▶ Enter (check if entered already) carrier setting in profile A (frequency, polarization, symbol rate, and mode). Set Viterbi and spectrum inversion values to auto. Check whether profile is switched on. If it is off – switch it on (de pr a en).
- ▶ Switch profile B off to eliminate its effect on the search operation (de pr b di).
- ▶ Set search range not less than 3000 KHz (demod search 3000).
- ▶ Reset LNB offset (demod search 0). In this case search range does not change.
- ▶ If antenna is not adjusted to the satellite, adjustment can be carried out using AGC readings (via USB console, Telnet or WWW-interface). When antenna is adjusted to some (any) satellite the AGC readings will decrease. The lower is the reading the more accurately antenna is adjusted. If the reading is greater than 900, check cable and application of power supply to LNB.
- ▶ Carrier searching at 250 KSps within the bandwidth 3000 KHz (the slowest case) takes about 30 seconds. If there is no reception and AGC is less than 900, verify whether the antenna looks at the proper satellite.
- ▶ Make sure to receive the carrier. Demodulator will change to the UP state and will generate a message to the console.
- ▶ Compensate frequency offset (see demod compensate command).
- ▶ Narrow search bandwidth up to 700-1000 KHz.
- ▶ Save the configuration (config save).
- ▶ You can achieve maximum sound-to-noise ratio by the antenna fine adjustment, although it is better to perform fine adjustment of Rx/Tx antennas using transmitter

mode – i.e. with reference to maximum of your carrier on the other end of the link.

2.6 Burst demodulator

Burst demodulator router is purposed to receive collective TDMA satellite channels, sent by other routers.

This demodulator is used at the Central Station (Hub) for receiving Inroute (return) channels from network terminals. One burst demodulator supports reception of single TDMA channel. The required number of Inroute channels supported by Hub formed by cascading a respective number of satellite routers.

TDM/TDMA terminals with activated Half Mesh mode also use a burst demodulator to interact with other Hal Mesh network terminals in one satellite hop and without transit via Hub. In this mode, the network may have any topology (e.g. star of stars, partly meshed, fully meshed and etc.).

Also, the burst demodulator is used in Full Meshed TDMA networks for receiving a common collective network carrier.

Satellite terminals with activated Burst Demodulator have to be equipped with PLL LNB convertors instead of low-stable DRO LNB. Also, the link budget of such network has to ensure that TDMA carrier is properly received by all network terminals with activated burst demodulator.

The burst demodulator is disabled in the basic configuration of the router. The respective software activation key is necessary to enable the burst demodulator. Please refer to respective addendums to this manual for further details about operations of the burst demodulator.

2.7 Modulator

UHP-1000 router modulator is designed to form carriers to transmit IP-packets and service information. The modulator can operate in two basic modes – continuous (SCPC) when channel is transmitted in physical (but not logical) DVB-S format and burst transmitting short (0.5 – 20 ms) bursts with information coded in the generic protocol. Connected to the modulator output connector is a satellite transmitter (BUC) or via IF combiner if BUC is shared by several systems.

Table 5 Modulator parameters

Parameter	SCPC	Outroute/Hub	Remote
modulator frequency	user	user	auto
modulator symrate	user	user	auto
modulator FEC	user	user	auto
modulator inversion	user	user	user
modulator level	user	user	user
modulator tx	user	user	user
modulator power	user	user	user
modulator reference	user	user	user
modulator tlc mode	user	user	user
modulator tlc range	user	user	user

The modulator can generate 10 MHz reference signal for the transmitter synchronization, and supply 24 VDC with the current of up to 2 A. When switching such signals it essential that the following be taken into account:

10 MHz REFERENCE SIGNAL SHOULD BE GENERATED ONLY BY ONE SOURCE IN THE CABLE SYSTEM. TWO SIGNAL ARE SUPERIMPOSED THUS LEADING TO PERIODIC FADING AND HENCE TO COMMUNICATION FAILURES.

CABLE IMPEDANCE COMING TO TRANSMITTER CAN LEAD TO A HIGHER BUC CURRENT CONSUMPTION. BUC TRIES TO CONSUME FIXED POWER AND IF PART OF THE VOLTAGE DROPS ACROSS THE CABLE, BUC WILL HAVE TO BE FED WITH LOWER VOLTAGE AND WILL CONSUME HIGHER CURRENT. EXAMPLE: BUC CONSUMES 40 W. CURRENT THROUGH THE SHORT CABLE IS 1.66 A. IF BUC IS CONNECTED VIA A 2-OHM RESISTANCE CABLE, THEN ACCORDING TO OHM'S LAW $(40/I) + (2*I) = 24$, AND $I=2$ A (!). INEXPENSIVE DOMESTIC CABLES FEATURE RESISTANCE PER UNIT LENGTH OF ABOUT 3 TO 4 OHM PER EVERY 100 M.

In some router operation modes, certain modulator settings are missing. This is due to the fact that settings are received from the network central station and are applied automatically.

Modulator frequencies are specified in KHz. You can recalculate them to satellite frequencies if you know BUC LO frequency (See Figure 15).

Modulator control commands:

----- Modulator parameters
modulator frequency 950000-1700000 - Central frequency (KHz)

Modulator central carrier frequency in kilohertz. The recommended maximum frequency should not exceed 1550 MHz. Working with higher frequency is possible, but not guaranteed and should be tested before use.

modulator symrate 1-34000 - Symbol rate (KSps)

Carrier symbol rate. Bit rate can be calculated based on the current FEC value. Modulator shows it in its statistics data.

modulator fec uncoded 1/2 2/3 3/4 5/6 7/8 - FEC mode

Viterbi coder error correction mode in the modulator.

modulator inversion off on - Spectrum inversion
--

Spectrum inversion in transmit mode. If you know that BUC or satellite inverses spectrum, it is worth to switch inversion on in transmit mode so as to receive non-inverted signal on the other side.

modulator power off on - Modulator BUC power

BUC 24 V supply voltage control applied to modulator output.

modulator reference off on - Modulator 10 MHz output

10 MHz reference signal control applied to modulator output.

modulator tx off on pure-carrier balance - Tx carrier control
--

Transmit mode.
off - Transmit off
on - Transmit on
pure-carrier - Transmission of unmodulated carrier
balance - Transmission of interchanging 0, 1 (on the spectrum analyzer it is in the form of two spikes with frequency shift equal to the symbol rate) used for evaluation of the residual carrier and intermodulation values

modulator level [0-360] - TX power level (x -0.1 dBm)
--

Transmission signal level from -36 dBm to 0 dBm. The greater value corresponds to the lower level. The router ensures the range from -30 dBm to -5 dBm but the circuitry allows, in the lower portion of the frequency range, level adjustment over a wider range. It has been decided not to eliminate this capability for users. A spare decibel may turn out to be very important for some people.

When an automatic level control system (TLC) is turned on level variation does not result in a change in the output level but during subsequent restart the modulator first will set this new value as the initial one and only then will adjust it according to the TLC algorithm.

If the command is entered without parameters, interactive level control is activated and it is convenient for the values selection and adjustment.

UHP#mo le VAL:380 1:-10 2:-1 3:+1 4:+10 Q-quit

Keys 1 and 2 can increase the level by 1 dB and 0.1 dB, respectively, whereas keys 3 and 4 can be used to decrease the level by 0.1 dB and 1 dB. To exit use "q" key.

```
modulator tlc range 50-360 50-360 - Max/min allowed auto TX level
```

The levels range where TLC is allowed to control transmission signal level.

The upper limit for cases when most of transmitter power is used should be set by 1 decibel above the BUC compression point, whereas the lower limit should be placed 8-10 decibel below the upper limit. If transmitter power is substantially higher than the standard mode requires, the upper limit should be placed 3 to 4 dB above the clear sky optimal value.

```
modulator tlc mode off|on - Automatic transmit level control
```

Switching automatic transmission level control on.

Modulator settings and operation statistics can be printed using the "show interface modulator" command:

```
UHP# sh in mo
Modulator interface is UP
Last U->D: never           U->D transitions: 0
Last D->U: +00:00:02      Counters cleared: never
----- Modulator settings -----
Freq: 1497220  SR: 2105           SetLvl: -22.0  Max: -15.0  10M: OFF
FEC: DVB 2/3  BR: 2572  TX: ON      OutLvl: -22.0  Min: -25.0  24V: OFF
-----
Rate/bps: 0
LOW  Packets: 0           Bytes: 0           Q_len: 0           Drops: 0
MED  Packets: 0           Bytes: 0           Q_len: 0           Drops: 0
HIGH Packets: 0           Bytes: 0           Q_len: 0           Drops: 0
```

Freq - frequency in KHz
 FEC - error correcting coder mode
 SR - symbol rate
 BR - user bit rate (calculated based on SR and FEC)
 TX - transmit mode (ON, OFF, PURE, BALANCE, /INV, /TLC); spectrum inversion switching on and TLC are also displayed here
 SetLvl - transmit level set by the user
 OutLvl - current transmit level, with TLC correction
 Max - maximum permitted level for TLC
 Min - minimum permitted level for TLC
 10M - switching 10 MHz signal on
 24V - switching BUC power supply on
 Rate/Bps - current traffic rate in transmit mode

Furthermore, statistics show information on three priority packet queues. Traffic from IP-router is fed to these queues. The first queue to be able to transmit a packet is the HIGH queue, and if it is not empty – then MED queue, and if it is empty – then the LOW queue. In the TDMA mode, prioritization is implemented on the packet fragment level, while in the SCPC mode - on the whole packet level.

For each of the queues, shown in the display is the number of packets and bytes that have passed through it, the queue length in bytes (this permits to judge on the overload and delays), as well as the number of packets lost from the queue due to serious overload with traffic. Maximum queue depth is about 700 packets.

Counters can be cleared using the "clear counters modulator" command.

2.8 IP traffic processing and routing

2.8.1 SVLAN overview

UHP-1000 routers make use of a special protocol to transmit information via the satellite. Requirements to such protocol are minimal overhead and a possibility to split and group data streams. With the UHP-1000 routers, this protocol is named SVLAN.

SVLAN channels are similar to the VLAN notion in Ethernet but it is simpler – it is just "pipes" with numbers. If you send traffic into such a pipe (SVLAN) at the modulator, then at

the other link end you will receive these packets to be dealt with by the IP-router, provided you set the same SVLAN number for reception.

SVLAN with number 0 differs from others by that traffic through it is transmitted without additional headers at all, thus providing the highest transmission efficiency. The rest SVLAN (1-1020) add two bytes to each packet.

Into one SVLAN one can, using router facilities, route the required number of networks, each of them having its own priority level.

2.8.2 IP-router

UHP-1000 routers implement a standard IP-router supporting static routing. The routing table can contain the following records:

- IP-address on LAN
- Statistical route in the LAN direction
- IP-map – a route to the modulator in SVLAN
- SVLAN Receive – a command to receive SVLAN from one of the demodulators

Records in the Table are arranged according to the network mask. The first ones are records with mask /32. Any of the records can contain VLAN and then it is referred to the Table of the relevant VLAN and will work only in it.

Altogether, the Table can contain up to 1,000 records. Routing speed is practically independent of the number of records.

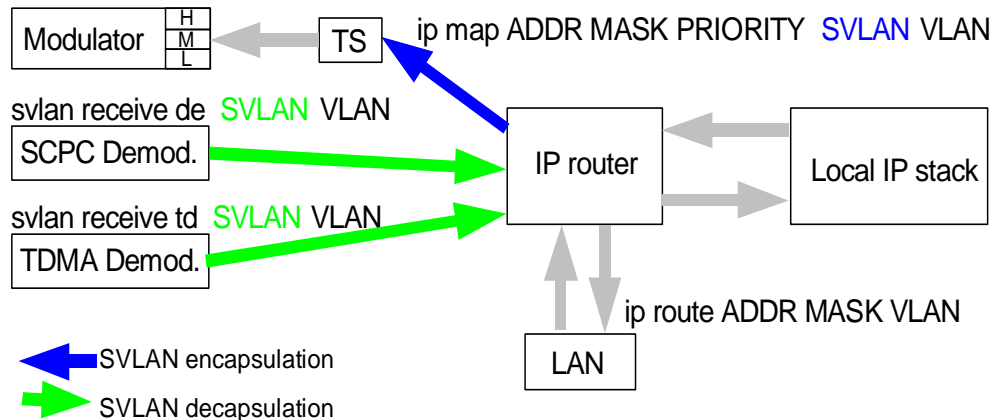

Figure 17 Routing layout with examples of commands

Records to the route Table come from two sources – local settings and the routing table received from the Hub. Routes from Hub are always entered in the routing table. Local configuration routes are entered only if it is permitted from Hub or if routers routing remote control system is switched off on Hub. On Hub, you can allow or prohibit, for each individual router, reception of various routing records from the local configuration. For example, you can allow local administrator of the router add static routes but prohibit changing IP-addresses and SVLAN.

All records are provided with counters of packets that have been routed as per these records. This will make diagnostics easier.

UHP-1000 router has no limitations on overlapping the addresses, incompliance of masks, etc. This makes it possible to obtain more capabilities from routers but these capabilities should be used with care.

2.8.3 Router control commands

```
----- IP parameters
ip address IP_ADDR IP_MASK [1-1020] - Add IP address to interface [VLAN]
```

Adding IP-address to the Ethernet interface. The address and mask are separated with a blank. Multiple addresses can be defined. If non-zero VLAN is specified then the address is added to the route Table of this VLAN.

```
ip route IP_ADDR IP_MASK IP_ADDR [1-1020] - Add static route [VLAN]
```

Adding static route.

Availability of the route destination address is not checked.

```
ip map IP_ADDR IP_MASK ml|mm|mh|md 0-1020 [0-500] [1-1020] - Route network to
TX SVLAN [TrSh] [VLAN]
```

Route for transmitting IP-network via satellite. Parameters:

ml|mm|mh|md - Transmit priority (High, Medium, Low, DSCP).

0-1020 - SVLAN number (0 – transmit without SVLAN encapsulation).

0-500 - Traffic Shaper channel number to pass the traffic. Optional parameter. If it's not specified, the traffic will go via channel 0 the configuration of which should be checked at least once to avoid surprises.

1-1020 - VLAN number the record is referred to.

```
svlan receive demod|tdma 0-1020 [1-1020] - Add RX SVLAN [VLAN]
```

Add SVLAN reception from one of demodulators. When VLAN is specified the traffic will go to its route Table instead of the basic one.

```
ip delete IP_ADDR IP_MASK [1-1020] - Delete IP address, route or map [VLAN]
```

Delete address, route or map.

```
svlan delete demod|tdma 0-1020 [1-1020] - Delete SVLAN [VLAN]
```

Delete record on SVLAN reception.

```
udp ports 0-65535 0-65535 - UDP ports mapping for RTP compression FROM TO
```

Add UDP destination ports range for SVLAN-encapsulation, where the router will try compressing RTP packet headers. If the range covers more than 200 ports, then this range value is rounded down to the nearest hundred.

Example:

1000 – 1100 -> 1000-1100

1000 – 1200 -> 1000-1200

1000 – 1220 -> 1000-1300

2250 – 3100 -> 2250-3050

```
udp delete 0-65535 - Delete UDP port mapping
```

Remove port range.

```
rip-advertise none|static|maps|all - RIP route types to advertise
```

Should static routes and maps be announced as per RIP2-multicast protocol.

The router will not announce default gateway, even it is not set. Incoming RIP messages are ignored.

```
rip next-hop IP_ADDR - RIP next hop to advertise
```

Set NEXT HOP parameter for RIP announcements.

Router settings and statistics can be printed out using “show ip” command. Asterisks in front of records mean that the relevant record is assigned from Hub.

```
UHP#sh ip
T VLAN Network/Source Mask Destination TrSh Packets Bytes
```

T – record type (A-IP address, R-statistical route, M-map, V- SVLAN reception)

VLAN –VLAN number the record is referred to.

Destination – where packets are passed.

TrSh – Number of Traffic Shaper stream which the traffic will go through (for map records).

Packets, Bytes - Number of packets and bytes which have used the given record (values are reset to zeros after any changes in the route Table)

A	10.0.0.12	/24	Ethernet	-	105	5460
----------	-----------	-----	----------	---	-----	------

IP-address on LAN-interface. There was traffic on it.

command - ip ad 10.0.0.12 /24

R	10.0.1.0	/24	10.0.0.10	-	0	0
----------	----------	-----	-----------	---	---	---

Static route. Bytes counter does not work with such records, only packets are counted.

command - ip ro 10.0.1.0 /24 10.0.0.10

A 30	192.168.0.1	/24	Ethernet	-	0	0
-------------	-------------	-----	----------	---	---	---

One more IP-address but it belongs to route Table with VLAN=30.

command - ip ad 192.168.0.1 /24 30

M 30	192.168.1.0	/24	Mod/LOW ->200	0	0	0
-------------	-------------	-----	---------------	---	---	---

Incoming packets with VLAN=30 on the relevant network will be transmitted via modulator with SVLAN=200, with low priority via channel 0 Traffic Shaper.

command - ip ma 192.168.1.0 /24 ml 200 0 30

M	30.0.0.0	/23	Mod/HIGH->0	0	0	0
----------	----------	-----	-------------	---	---	---

command - ip ma 30.0.0.0 /23 mh 0

V	Demod. RX->0	IP Router	-	0	0
----------	--------------	-----------	---	---	---

Receive SVLAN 0 with SCPC demodulator.

command - sv re sc 0

V 30	TDMA RX->200	IP Router	-	0	0
-------------	--------------	-----------	---	---	---

Receive SVLAN 200 with TDMA demodulator into route Table VLAN 30

command - sv re td 200 30

Unroutable: 0	Last: 0.0.0.0 -> 0.0.0.0	Screened: 0
----------------------	------------------------------------	--------------------

Number of packets that failed to be routed, as well as IP-addresses of the source and destination of the last of such packets. .

Screened – Counter of packets that tried to get directly to the modulator from demodulator and have been dropped.

DSCP: 0:H.H..... 8:..H..... 16:H...H.. 24:.....
--

DSCP values map that have to be treated as high priority ones. In this case IP-packets with DSCP field equal to 0, 2, 11, 16 and 21 will be transmitted with high priority (with map records with md priority).

UDP/RTP ports: 1000-1100

List of ranges of UDP ports for compression of RTP headers.

To clear statistics you may use "clear counters ip" command.

2.8.4 VLAN support

UHP-1000 routers support most of the IEEE 802.1q standard capabilities. Support for multiple route Tables associated with VLAN values on the Ethernet interfaces is provided.

UHP-1000 router can receive traffic over LAN with VLAN tag 1-1020 and transmit it to the satellite with the assigned SVLAN value. Reception for satellite and traffic routing to LAN with tagging added is also possible. VLAN 0 is untagged.

Within UHP-1000 router, reception of traffic over one VLAN and immediate resending it back to LAN over another VLAN without transmitting it via a satellite is impossible.

To summarize, the user can do the following:

- Decide which VLAN to use to receive traffic from LAN (or receive untagged to the

main Table, with VLAN=0), having IP-address entered into route Table of this VLAN.

- Decide how to route this traffic over to satellite, having map commands entered into Table of this VLAN and SVLAN number for transmission.
- Mix traffic from various VLANs, routing IP networks from VLAN routing tables into the same SVLAN.
- Direct traffic from one VLAN by separate routes into different SVLANs.
- The command routing IP network to SVLAN always features one of the four priorities (Low, Med, High, and DSCP), so the user can route networks for transmission with different priorities to the same SVLAN.

On the other end of the channel:

- Decide to which routing table of (which VLAN) to receive SVLAN from the satellite.
- Decide where route it afterwards (to LAN) with VLAN tagging of this Table (or without tagging if the main Table with VLAN=0 performed reception).

2.8.5 IP traffic screening

Satellite channels by nature are broadcasting. In this case in a point-to-multipoint topology network, IP-packets transmitted to the satellite from Hub can be received on many terminals simultaneously. Since different networks are routed to different terminals, it is logical that each SVLAN be assigned to a separate direction, and this is what is usually done. But it may happen so that due to the router wrong configuration or in case of mixing routers traffic into one SVLAN (e.g. into SVLAN 0 for a better channel efficiency), not all traffic received via SVLAN will be lead out from the router to LAN (there will be no routes). If in this case the default route on the router is set to the Central Station, a routing loop may be generated, the result being that channels will be instantly overloaded with circulating packets.

To avoid this situation, UHP-1000 router is provided with a special mechanism - IP screening. This mechanism works as follows: each packet received from satellite gets a tag. If during routing this packet tries to go back to the satellite it will be dropped. Packets coming from LAN and generated by the router itself are not tagged and they have no limitations whatsoever.

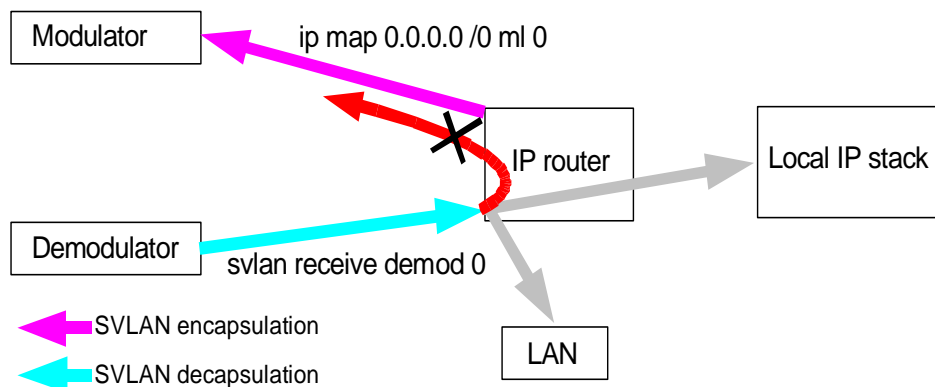

Figure 18 IP traffic screening

Router statistics (sh ip) is provided with a counter indicating how many packets have been dropped because of screening.

Packets directed to the modulator are at first encapsulated in SVLAN and then are placed into of the three priority queues LOW, MED, HIGH. There is the fourth queue with a still higher priority but it is used for service traffic and signaling. The queues work using a "hard" priority, i.e. packets from a lower priority queue are transmitted only when a higher-priority queue is empty.

Selection of the packet getting into the LOW or HIGH can occur also depending on the DSCP packet field value. The router understands DSCP values from 0 to 31.

2.8.6 Prioritization and DSCP

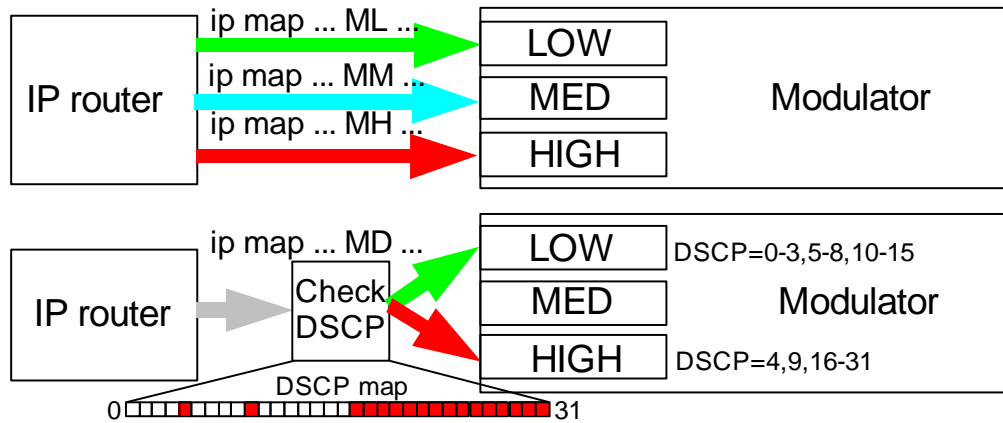

Figure 19 Prioritization of traffic on the modulator

2.8.7 Multicast routing

Group traffic support is implemented in UHP-1000 routers as follows:

To collect Multicast traffic from LAN to specified address you have to assign a map for this traffic on the modulator. The router will itself understand that the address (network) belongs to the Multicast range and will tune LAN to receive it.

At the other side, to transmit this traffic to LAN it is necessary (apart from the command to receive SVLAN used to receive this traffic) to assign a static route to the Multicast address (network) of the transmitted traffic, having selected, as the destination address, any address within the range of any of the IP networks assigned to the router. The device with such address may be missing, it is more important that the packets be routed to LAN.

2.8.8 Compressing RTP packet headers

When transmitting VoIP traffic by IP-protocol the size of headers of IP, UDP and RTP protocols (in total not less than 42 bytes) can exceed the size of the voice portion of the packet.

Transmission of such packets via a satellite is extremely inefficient with respect to bandwidth usage, hence use is made of compression of protocols headers based on the fact that only few fields change from packet to packet, and furthermore this change can often be predicted.

In most cases the router compresses packet headers to up to two bytes. To make compression work, it is essential that at the transmitting side (or at both sides) the ranges of UDP (destination) port packets that the router will try to compress be adjusted accordingly. Compression will work also in simplex mode (in one direction only). Packets passing successful compression will always be sent with high priority.

Statistics of the compression functioning can be made available using "show rtp" command.

```

UHP# sh rt
Transmit -----
Source_IP      Destination_IP  Plt  Errors
10.0.0.17      10.1.0.1      11   0
Receive -----
Source_IP      Port      Destination_IP  Port  TOS  Plt  Packets  Errors
10.1.0.1       4001     10.0.0.17      16011 0    11   1171    3
  
```

Statistics show addresses, UDP ports, Payload Type and packets TOS. Errors counter increases as packets are lost also in other cases when it is impossible to decode the packet compressed heading.

2.9 Traffic Shaper

Traffic shaper (TS) is intended for adjustment of the bandwidth occupied by data streams in transmitting via a satellite. TS is based on the streams concept – controlled “pipes” for traffic between router and modulator. Each stream is provided with three priority queues and a “hard” limitation in the traffic rate at the output, i.e. the stream behaves practically in the same way as a modulator. Prioritization of the stream queues is also adhered to. Packets from output streams arrive in the modulator queues with the same priorities (packets from LOW queue of TS arrive in the LOW queue of the modulator, etc.). Altogether there are 500 streams.

Each map-record in the route Table can allow traffic via some of the TS streams. One stream can accept traffic from different networks using several records including those with different SVLANs. If stream number is not specified on map-records, then their traffic goes via stream 0. By default, bandwidth of this stream is set to maximum. If the bandwidth is set to a lower value and it will be forgotten, a rather strange, at first sight, modulator behavior may be observed – when the channel is not loaded but traffic cannot fully occupy it.

If the rate of traffic entering the stream is greater than the stream bandwidth at the given moment then traffic is buffered to create delay during transmission.

Basic principles of TS operation:

- Tailoring committed information rate (CIR) for each stream
- If there is a free bandwidth on the modulator and streams are allowed to exceed CIR, TS will extend bandwidths of those streams that are overloaded
- Expansion proportional to CIR
- Expansion of streams is effected smoothly, proportionally to the free bandwidth of the modulator so as to avoid overloads, narrowing is effected more aggressively based on the same reason
- If modulator load approaches its limit, TS narrows the bandwidths of exceeding streams to lower the modulator load or to the values of their CIRs

Calculation and correction of the stream bandwidths is made every second, and that is why TS responds dynamically to the behavior and requirements of the network.

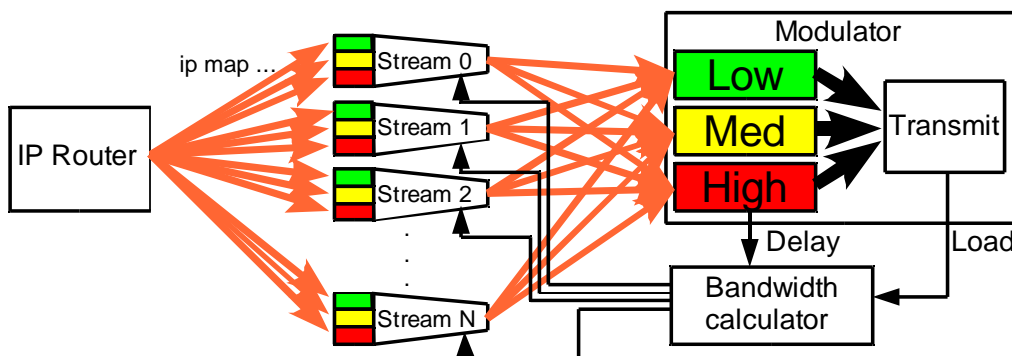

Figure 20 Principle of operation of Traffic Shaper

Examples of TS operation:

Two streams share a 800 Kbit/s channel. CIR of the green stream is 200 Kbit/s, that of the red one – 400 Kbit/s. Maximum stream bit rates are not limited. The blue line stands for general load of the channel. Dashed line means the desired stream bit rates.

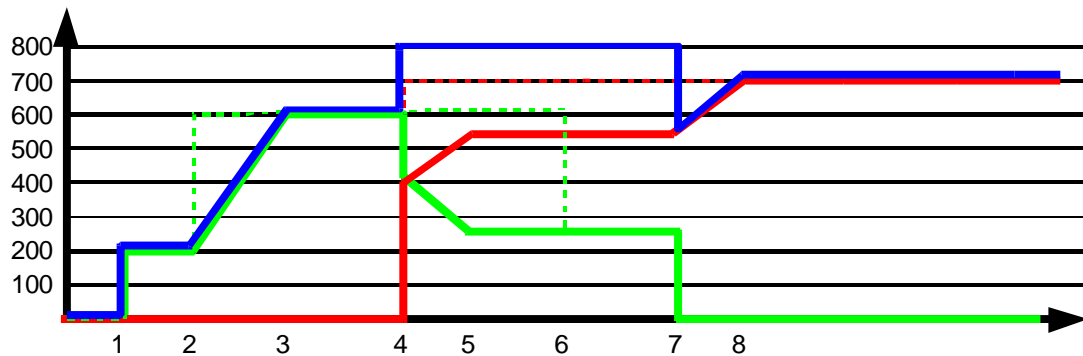

Figure 21 Example of Traffic Shaper operation

By points (Figure 21):

- Green traffic begins entering at 300 Kbit/s. This is within CIR limits and hence TS does not delay packets.
- Incoming green traffic bandwidth increases three-fold – up to 600K. Traffic begins to be delayed since the stream bandwidth is insufficient. As the load of the general channel is low, TS begins to smoothly expand green stream bandwidth until its overload is eliminated. Stream rate of increase is proportional to the "Slope Factor" which is set in the TS configuration.
- Green stream bandwidth is stabilized at 600K to pass the traffic without delay.
- Red traffic starts with 700K bandwidth. Gets immediately 400K (CIR). The channel gets overloaded. TS almost immediately narrows the green stream bandwidth up to CIR=400K to remove modulator overload. Since both streams are overloaded and want to get a wider bandwidth, a fair (proportional to their CIR) distribution of the bandwidth between them is initiated.
- The bandwidth is divided in proportion of 33% to the red stream (CIR=400K) and 66% to the green stream (CIR=200K). Channel load is close to 100%.
- Green traffic reduces to 250K. Nothing happens since its bandwidth is still wider than CIR.
- Green traffic ceases. Modulator load drops and TS starts to expand overloaded red stream.
- Red stream gets stabilized at 700K to transmit traffic without delay.

In this example adaptation of IP-protocols to the delay is not taken account of, otherwise the example would be too complicated but the algorithm is designed for this adaptation.

TS does not track the situation when the sum of assigned CIRs exceeds the modulator bit rate. In this case TS cannot guarantee CIR streams – this is just impossible, but anyway it will try to provide maximum fair distribution of the bandwidth.

TS adjustment commands:

----- Traffic Shaper parameters
shaper stream 0-500 0-64000 [0-64000] - TS stream CIR(Kbps) [MAXSPEED(Kbps)]

Stream parameter adjustment. Guaranteed bit rate (CIR) and optionally – maximum stream bit rate are set. If maximum bit rate is not set, stream bit rate will be tantalizingly constrained by CIR. Stream bit rates are measured in kilobit per second (1024 bit/s). When selecting stream numbers it is better to number them from the beginning and not to use too large numbers (numbering 100, 200, 300... is undesirable, better numbers are 1, 2, 3 or 2, 4, 6).

shaper delete 0-500 - Delete TS stream

Nulls stream parameters by switching this stream over to TS transparent algorithm.

shaper bandwidth 0-128000 - Composite channel bandwidth (Kbps)

Output bandwidth limit to which TS algorithm will reference to. This is not a tough (monitored) value but a desirable one – with sharp changes in traffic at the input, the TS output traffic may exceed this value. It is expedient to first set the TS bandwidth 5% less than the channel bandwidth and then correct it while observing the network traffic.

shaper slope 1-64 - Shaper algorithm slope factor

Relative non-dimensional coefficient (a multiple) monitoring how TS is adapting (increasing) streams bandwidth. Value 16 is optimum to begin with, and it can be corrected if necessary.

TS settings and statistics can be observed using “show shaper” command.

```
UHP#sh sh
Slope=16 Bandwidth(K)=64000 ModSpeed(Bps)=0(0%) ModDelay(s)=0.0
Strm| CIR.K Max.K | Spd.bps % | Del. | LowSp MedSp HigSp | Title
1 | 100 0 | 0 0 | 0.0 | 0 0 0 |
5 | 256 384 | 0 0 | 0.0 | 0 0 0 |
```

- Slope - Bandwidth adaptation coefficient.
- Bandwidth - Desirable TS output bandwidth.
- ModSpeed - modulator traffic rate in kilobits and in per cent of the modulator maximum possible bandwidth (physical).
- ModDelay - Delay on the modulator in seconds (queues length / bit rate).
- Strm - Stream number.
- CIR.K - Assigned certified information rate.
- Max.K - Assigned maximum permissible bit rate.
- Spd.bps - Current bit rate at the stream output in bits per second and per cent. Per cent is calculated with reference to CIR.
- Del - Delay on the stream is seconds (queues length / bit rate).
- LowSp,... - Bit rates in each queue inside the stream.
- Title - Stream name (for CS). Setting is performed only from NMS and transmitted to the router on the network.

2.10 Satellite Pointing

Satellite routers have built-in tools for pointing the antenna to the satellite. The router provides actual information about overall input signal level (RF Level), as well as the quality of the reception of the carrier (Eb/No) from the Hub (or carrier of another station in SCPC mode) when demodulators locks on such carrier. Such information can be obtained in real time via HTTP interface, a local console (command line) or as an analog DC signal.

Pointing procedure is common for any method of displaying the level of signal quality:

- Calculate expected elevation and azimuth (corrected accordingly to magnetic declination). Such calculations can be performed with EASTAR Calculation Tool available on the Documentation CD or can be downloaded from the Web.
- Direct the antenna toward the satellite. When installing the angle of elevation please take into account offset angle of parabolic antenna (specified in the description) or use an elevation scale of antenna.
- Access the information about actual signal level of satellite router with any of methods described below.

- Start moving antenna slowly in limited angle of elevation and azimuth. The value of the demodulator input level increases when antenna receives signal from any satellite. Signal peak means proper pointing to the satellite.
- After finding the peak of this signal by adjusting the azimuth and elevation, it is necessary to provide demodulator some time to search for and capture the carrier from the Hub. Search for the carrier with symbol rate of 250 ksps in the band of 3000 kHz (slowest case) may take about 30 seconds. If demodulator is unable to lock on a carrier for a long time it may mean that antenna is pointed to a wrong satellite and it's necessary to continue moving the antenna in search for another satellite.
- When demodulator locks on the carrier the router begin to show actual Eb/No level, the maximum of which is necessary to achieve by fine tuning the azimuth and elevation of the antenna.
- Once the satellite is found, it is necessary to tune the polarization angle in accordance with the procedures applicable to this satellite. Afterwards, the terminal may get a permission to start transmission. (see Section 2.7).
- You can reduce demodulator's scanning time by adjusting the frequency shift and narrowing the search range as outlined in the Section 2.5.5.

2.10.1 Pointing with HTTP assistance

"Pointing" window of the router displays information about the quality of signal reception (Figure 22) and simplifies the procedure of an antenna pointing.

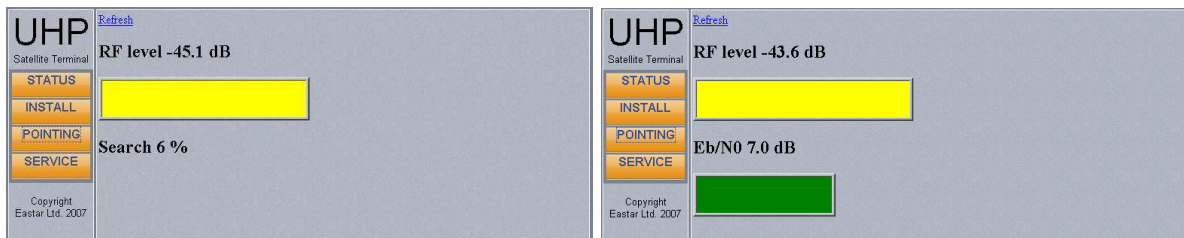

Figure 22 HTTP Information about the quality of signal reception

The information about demodulator's quality of reception is displayed in the graphical and textual form. Search phase is also shown below when demodulator is unlocked. Please allow demodulator to pass all search cycle before changing azimuth and/or elevation angle. When demodulator locks on the carrier textual and graphical information about level Eb/No will replace the information about search phase. Proceed with fine-tuning of antenna azimuth and elevation until a maximum of Eb/No level is achieved.

2.10.2 Pointing via management console

Pointing assistance via console is activated by "demodulator antenna" command. When such mode is active the console will display a string with actual information which is updated two times per second.

If there is no reception of the carrier yet, the string looks like this:

```
EASTAR # de an
  RFlvl   Max   Min      State   Eb/N0   Max   Min   Q-quit
  -45.1   -44.7 -45.1   Search-12%   4.1    4.1   4.1
```

When the demodulator is locked on the carrier the string looks like this:

EASTAR #	de	an						
RFlvl	Max	Min	State	Eb/NO	Max	Min	Q-quit	
-43.3	-43.3	-44.0	***Locked***	7.6	7.8	7.6		

The string shows the overall level of the signal from LNB. It reports the current RF level, as well as maximum and minimum peaks registered during the pointing assistance. Further, the demodulator state status: percentage of search circle when demodulator is unlocked.

or "Locked" message or the percentage of scanned strip search in the current cycle, or a message that the demodulator is found and adopted a signal.

When demodulator is locked on the carrier its "Status" change to "Locked and further three values represent- the Eb/No levels of demodulator (current, maximum and minimum).

Type "Q" to exit pointing assistance mode.

2.10.3 Pointing with analog reference signal

The router may output an analog signal via USB port equivalent to quality of reception of the demodulator. This voltage can be used for pointing the antenna to the satellite during installation or/and as a reference signal form automatic antenna tracking system.



Figure 23 Pinout of USB Console interface

The analog pointing signal is available on the Pin 1 of USB "Console" port (to be used with "Ground" signal on the Pin 4). In the standard mode the pin 1 used to deliver a 5 VDC power from the computer. When pointing feature is activated the pin 1 represents output voltage ranging from 0 to 3.3 volts. Such voltage does not interfere with standard USB port operations. Short-circuiting this signal to Ground is not critical, however input voltage above 5 VDC is not allowed.

Standard (analog or digital) voltmeter connected to this signal could be used as a reference toll for antenna pointing. Installer may use Tx coax cable to deliver such signal from the router (indoor) to antenna (outdoor) – this cable is not used while antenna pointing. Special adapters to connect the F-connector of coaxial cable to USB output and a voltmeter can be purchased from your local distributor or make by your own.

When this mode is active the voltage is changed within the following range:

- When demodulator the voltage is in-between 0 and 1 Volt proportionally to the overall Rx level of the demodulator;
- When demodulator is locked the voltage is proportional to Eb/No and ranging from 1 V to 3.3 V. Voltage above 1V is proportional to Eb/No with ration 10dB/1V, e.g. reception of the carrier with Eb/No signal of 5 dB will be represented as 1.5 V signal on USB port, 10 dB - 2V, etc.

The pointing mode is activated by the following command::

```
demodulator antenna [0-800] [0-800] - Antenna pointing mode [RF min] [RF max]
```

Two optional command parameters - the range of IF levels corresponding to the voltage range 0-1V. If omitted, the current level is taken as the minimum, and level 15dB higher than actual is taken as a maximum.

When activating the pointing mode while antenna is already pointed to the satellite the default minimum level may be set too high. It is not a problem if the intention is just fine pointing of antenna to the same satellite. However this may create a problem re-pointing the antenna to another satellite, because the reference level may not react on lower signals

when antenna is disoriented from the initial satellite. To prevent this, it's recommended to define the desired range manually.

2.10.4 Auto tracking signals during normal operations

When earth station antenna is equipped with auto tracking system it might be necessary to use analog reference signal from the router during normal operations. This feature of satellite router works in the background and provides analog signal that is proportional to Eb/No level of the demodulator. The output voltage in this mode is in the range from 0V to 3.3V only in proportion to Eb/No demodulator and aspect ratio can be defined by the user.

```
demodulator voltage 0-10 - Pointing signal output to USB, dB/V (0-off)
```

The ratio of dB/V is defined by parameter of the command. If, for example, this parameter is set as 5 dB/V then at 10 dB Eb/No signal will be represented as 2V. If you the ratio is set as 1 dB/V, then the output voltage will change from 0V to 3.3V once demodulator is locked. This mode is deactivated when ratio parameter set 0.

Current status of pointing mode is shown on the «show system» status report:

```
HUB-UNIT_2# sh sy
UHP VSAT Terminal Software Version 2.2.10-9 (16.12.2009) SN: 00001602
Uptime: +03:24:20 CurrentTime: +03:24:20 TimeShift: 0
RateAvgTime: 5 BuffersFree: 1299 NoBuffer: 0
CPUload: 27 % IdleTimeout: 600 Temperature: 35c
LastTelnetIP: 10.0.0.100 AutoRestartDelay: 0
PntngVoltage: 0 dB/V
```

2.11 Operations

2.11.1 Modes of operations

UHP-1000 Routers support several modes of operations:

- **SCPC** –SCPC modem
- **REMOTE** –TDM/TDMA terminal
- **HMESH** –TDM/TDMA terminal with HALF MESH support*
- **HUB** –TDM/TDMA Hub*
- **OUTROUTE** – additional Outroute for TDM/TDMA Hub*
- **INROUTE** – additional Inroute for TDM/TDMA Hub*
- **FHUB** – master station of FULL MESH network*
- **FREM** – slave station of FULL MESH network*

The modes of operations marked by (*) require special software activation key.

Detailed information about HUB, OUTROUTE, INROUTE and HMESH modes of operations is available as a separate manual – “EASTAR TDM/TDMA HUB” [RD.IOMHUB.EN2.3]. “Full Mesh EASTAR Networks” [RD.IOMFM.EN1.0] manual contains detailed description of FHUB and FREM modes of operations.

2.11.2 Switching between modes of operations

Selecting the respective mode of operation is performed by the following command:

```
----- Router control
unit mode scpc|hub|outroute|inroute|remote|hmesh|fhub|frem - unit mode
```

This command has to be followed by saving the configuration and router reboot.

TDM/TDMA terminals with activated HM software option can be switched to Half Mesh mode by "unit mode hmesh" command. Actual settings of Tx and Rx Inroute channels could be verified with "show tdma" command and if necessary can be modified with "tdma tx inroute X" and "tdma rx Inroute X" commands.

2.11.3 Exploitation

UHP-1000 Routers belong to the class of unattended equipment and during its operation does not require any special staff exploitation. When operated as SCPC station or TDM/TDMA terminal the satellite router does not require any changes of settings or it is configured remotely from the Hub. The tasks of operational staff are limited to the following:

- Monitoring of climatic environment of operation, ensuring the absence of dust, preventing the ingress of moisture on the surface of the device. Should provide unrestricted air access to router for cooling.
- Cables connected to the device must not suffer any significant impact on the connections of the router. All connectors must be properly attached and secured.

2.11.4 Troubleshooting

Table 6 Troubleshooting guide

Symptoms	Possible reasons	Actions
Router doesn't work	AC power beyond the limits of allowed values	Check AC power voltage
	Power cord is broken	Check PSU cables and output voltage of PSU. Replace a cable.
	Power Supply failure	Check PSU cables. Verify if output DC Voltage is in nominal range. Replace PSU module
	Router Failure	Check PSU cables. Contact your nearest dealer or service center for advanced support.
ERROR indicator lights constantly after power on.	Router can't start the software	Press RESET button on the rear panel of the router. Contact your nearest dealer or service center for advanced support.
Router restarts every 3-5 seconds.	Short-circuit in transmit cable	Disconnect and check Tx cable
	Software failure	Reset software to factory defaults
No reception from the satellite (indicator LOCK is off, single flashes of ERROR indicator)	Incorrect configuration	Check Rx frequency and symbol rate (see section 2.5).
	IF cable failure	Check Rx cable and make sure that its connectors are properly connected to the LNB and the router.
	LNB is not powered	Check if LNB power is switched on (see section 2.5.3) Disconnect Rx IF cable from LNB and make sure that 12-18 VDC is available on the connector. Check Rx level in the statistic of the demodulator.

Symptoms	Possible reasons	Actions
	No carrier on the satellite or its level is insufficient.	Verify availability of the carrier and its level with spectrum analyzer. Contact Hub administrator and investigate if the carrier is properly transmitting and local weather conditions not attenuate the signal.
	Low Rx carrier level	Measure carrier signal to noise level with a spectrum analyzer. Verify if antenna is properly pointed to the satellite and there no obstacles in the direction to the satellite. Check the integrity of the film of antenna's feed horn and absence of moisture in it.
	LNB failure	Replace LNB to the spare one
High rate of errors of Rx path (LOCK indicator is not lighting constantly)	Bad weather conditions	The quality of reception may temporary decrease during intensive rainfall, for, thunderstorm cloudiness. Check if there is no snow or ice on the antenna surface and on the feed horn.
	Low signal to noise level	Check Eb/No in demodulator's statistics (See section 2.5.4). Verify if antenna is properly pointed to the satellite and there no obstacles in the direction to the satellite. Check the integrity of the film of antenna's feed horn and absence of moisture in it.
	Low Rx carrier level Interferences	Check Eb/No in demodulator's statistics (See section 2.5.4). Contact Hub administrator and investigate if the carrier is properly transmitting and local weather conditions not attenuate the signal
Station is not transmitting (Reception is normal: LOCK indicator is lighting, but TX indicator is off)	Wrong network setting	Check Tx frequency and symbol rate of the modulator. Make sure that transmission is enabled (see Section 2.7)
	Transmission of the terminal is not allowed by Hub (only for TDM/TDMA terminal)	Contact Hub administrator
Station is not transmitting (Reception is normal: LOCK indicator is lighting, TX indicator is blinking, but transmission is not received by Hub/opposite station)	IF Tx cable failure	Check Tx cable and make sure that its connectors are properly connected to the BUC and the router.
	BUC is not powered	Check if BUC power is switched on (see section 2.7) Disconnect Tx IF cable from BUC and make sure that 24 VDC is available on the connector.
	BUC failure	Replace the BUC on the spare one
Other symptoms	Other reasons	Contact your dealer or service center

2.11.5 Configuration management

UHP-1000 router configuration contains in configuration profiles. There are three profiles – the current and two saved ones. The current profile is dealt with by software of the router and changes in its configuration are made by the user. When the router is rebooted the content of current profile is lost. The saved profiles with numbers 0 and 1 are written in the non-volatile memory (flash) and are not changed during reboot operation. After switching on or restart the router usually copies the saved profile 0 in the current profile (loads the configuration). Profile 1 can also load if it is set so in the loading mode settings (see the relevant Chapter). The user can at any time copy the current profile in one of the saved ones.

Profile 1 can be used to create a working configuration copy prior the experiments are initiated.

Configuration management commands:

```
----- Configuration management
config description STRING - Describe current configuration
Sets configuration textual description displayed on the "show memory eeprom" command.
```

```
config load default - Load default configuration
Loads default settings. (IP=192.168.222.222/29).
```

```
config load 0-1 - Load configuration from specified profile
Loads one of the saved profiles in the current one.
```

```
config save 0-1 - Save current configuration to specified profile
Saves the current profile (zero at the command's end may not be entered).
```

```
show config - Show current configuration
Prints out current configuration.
```

```
show memory ram|flash|eeprom - Show memory state
Prints out configuration profile list in eeprom.
```

2.11.6 Events (LOGGING)

UHP-1000 router generates messages with the changes that show the router subsystems state. These messages are as follows:

- System messages on restart, saving configuration, etc.
- Messages on changes in the interfaces state
- Messages on changes in the stations status (for CS).

Examples of events:

```
+00:00:01 Interface Demodulator enabled
+00:00:01 Interface Modulator enabled
+00:00:01 Interface Modulator UP
+00:00:02 Interface Demodulator UP
```

The first to be displayed is the time stamp. If the router time is synchronized with the Hub (this occurs automatically), the current time is generated with the account of the time zone which is set on the router. If synchronization is missing, the time stamp starts with the + sign to signify the time that have passed since the router was switched on.

All messages are sent to the current console, plus part of them that has been selected by the user (by default – all), written in the non-volatile memory and saved during restarts.

```
show log - Display logs
Look message log through (old messages printed first).
```

```
clear log - Purge logs
```

Clear the log.

```
logging interface|demod|config|system enable|disable - Logging events
```

Permit or prohibit entering various message types in the log.

2.11.7 Limitations to access to the router

UHP-1000 router is provided with two privilege levels – User and Administrator. The User has access to the entire statistics but cannot change router configuration. Two passwords to log in the router are set. User password closes access to the router over Telnet and console. If, in this case, Administrator password is not set, by entering user password the logging-in person obtains administrator access. This is the most convenient mode. If it is necessary to differentiate the access to the router on both levels, you have to issue the «admin» command and enter the second password to obtain administrator rights. In the latter mode, if only administrator password is set, anyone can log in without password and see statistics, and for the administrator mode – make use of the «admin» command.

These passwords are used also for WWW-access.

```
admin - Switch to Administrator mode
```

Switch over to administrator mode.

```
password user|administrator - Set passwords
```

Change or switch off password. If you afterwards press “enter” button two times, the password will be reset.

```
exit - Log out from console
```

Exit from remote or console session.

2.11.8 SNMP protocol

UHP-1000 router supports SNMP protocol versions V1 and Community-based V2. The following SNMP classes are supported:

.iso.org.dod.internet.

management.mib2.

system.

...

interfaces.

...

private.enterprises.EASTAR.uhpV22.

...

Information on variables can be obtained from the MIB file supplied with the router or from EASTAR NMS.

```
----- SNMP parameters
```

```
snmp community read|write STRING - Set community strings
```

Defining SNMP passwords for reading and writing (by default “public” and “private”).

```
snmp access IP_ADDR IP_ADDR - Allow access from
```

Set up of IP-addresses from which the router will receive SNMP requests. Zero address (0.0.0.0) means that this value is not used. With both zero addresses access over SNMP to the router is fully blocked. If the first address is entered as 255.255.255.255, the access to the router will be possible from any IP-address.

```
show snmp - Display SNMP parameters
```

Display SNMP statistics.

```
UHP#sh sn
Read community - public          Illegal IP address - 0
Wrt. community - private        Wrong rd.community - 0
IP permitted 1 - 0.0.0.0        Wrong wr.community - 0
IP permitted 2 - 0.0.0.0        No variable in MIB - 0
Input requests - 0              Table out of index - 0
```

The first row contains SNMP settings and the number of requests received by the router.

Illegal IP address - Number of requests from non-permitted IP-addresses.

Wrong community - Number of requests with a wrong password (community).

No variable in MIB - Non-existing variable is requested.

Table out of index - Table value beyond the Table scope is requested.

2.11.9 Additional commands

```
watchdog reset|interrupt - Watchdog timer overflow action
```

Debugging service command.

```
reboot - Restart device
```

Router reboot. If configuration has been changed but not saved, all the changes will be lost.

```
time shift -24-24 - Local time zone
```

Difference in time zone with Hub.

2.11.10 Controlling router status

Enter router's IP address into Internet browser to access to connect to a monitoring and control page of the router (see Figure 14). Switch to the "Status" page for actual status of the router and its interfaces. The page will be automatically updated every 5 seconds. "Refresh" link allows manually updating the page on request.

Alternatively, the current status of the router can be accessed through a console with the following commands:

```
show interface ethernet|tdma|demodulator|modulator - Interface stats
```

Displays settings and statistics of respective interface

```
show log - Display logs
```

Displays a log of events (from latest to newest)

2.11.11 Traffic diagnostics

```
----- Diagnostics
ping IP_ADDR [1-1000000] [36-1470] [1-10000] - IP Number Size Interval(ms)
```

Sending PING request. The router can send up to 1000 packets per second.

Packet size (In contrast to WIN, LINUX) should be specified together with IP and ICMP protocol headers.

Example of PING command:

```
EASTAR # ping 10.0.0.1
SRC: 10.0.0.13 -> DST: 10.0.0.1 VLAN: 0
5 packets of 40 (12+8+20) bytes every 1000 ms (320 bps)
-----
Reply 1    TTL: 30    VLAN: 0    RTT: 4
Reply 2    TTL: 30    VLAN: 0    RTT: 1
Reply 3    TTL: 30    VLAN: 0    RTT: 1
Reply 4    TTL: 30    VLAN: 0    RTT: 1
Reply 5    TTL: 30    VLAN: 0    RTT: 1
-----
```

```
5 packets transmitted; 0 packets lost (0%) RTT (ms) min/average/max: 1 / 1 / 4
```

```
traffic-generator IP_ADDR 1-10000 36-1470 - IP packets/second packet_length
```

Switches traffic generator on. Apart from IP-address you have to set the number of packets per second and the size of packets.

`traffic-generator off` - Disable traffic generator

Switches traffic generator off.

Traffic generator sends same PING requests to the relevant address. In difference to PING the generator operates in the background mode and does not interfere with entering the commands, features no statistics and is intended for diagnostics with reference to counters on interfaces.

2.11.12 Powering off

To power the router off the Power Supply should be disconnected from AC power. If the device is powered by a low-voltage DC source, it can be powered off by disconnecting the DC cord from DC IN connector of the router.

2.11.13 Safety instructions for operations

- ☞ Connect and disconnect any cables only when router is powers off;
- ☞ Do not block ventilation holes of the router, as this could lead to overheating of the device;
- ☞ Clean the router by dry cloth, do not use liquid wipes or cleaners;
- ☞ Router must be installed on a stable and flat surface;
- ☞ Do not install on the router or near any glasses, vases and other containers containing liquid;
- ☞ Do not try to repair the router and not use it for other purposes;
- ☞ There no serviceable components inside, opening a case is not permitted;
- ☞ Servicing by qualified personnel only;

2.11.14 Actions in case of fire

In case of fire or any smoke of the router please immediately power off the device and if necessary, use extinguishing tools that are intended for electrical circuits.

3. EXPLOITATION

3.1 Technical maintenance

UHP-1000 Satellite Routers do not require any regular maintenance throughout its lifetime. All the parameters that are subject to change during operation (e.g. signal level, the delay to the satellite, etc.) are automatically controlled and compensated by embedded software. Time to time satellite routers may require updating/upgrading the software. Such updates are just recommended by manufacturer, which is performed at the discretion of the user.

3.2 Router software

One of the key advantages of UHP-1000 satellite routers is the ability to increase its functionality just by software updates. Software updates also include corrections of any known bugs and improve the algorithms of the system.

The updated software can be installed in the satellite router by the user. Also, such update can be performed by any authorized service center. In most cases, updating is carried out remotely without the need to dismount and disable the equipment.

Information about newest software updates can be obtained from any dealer, authorized service centers or online WWW.ROMANTIS.COM.

3.2.1 Software boot management

EASTAR software (SW) is placed in the non-volatile memory (flash memory). For convenience and wider capabilities the router flash memory can contain up to three different SW versions. SW is written in the memory banks. Memory banks are numbered from 0 to 3. Zero bank contains a loader designed for selecting of which of the banks should be downloaded during start (other functions of the loader are inaccessible to the user). Bank content example:

```
UHP# sh me fl
Bank 0: UHP boot loader      Version:00010401   Length:10932   Checksum:OK
Bank 1: UHP TDMA software   Version:00020203   Length:342852  Checksum:OK
Bank 2: UHP TDMA software   Version:00020101   Length:247972  Checksum:OK
Bank 3: UHP Test software   Version:00020011   Length:243312  Checksum:FAILED!
Default load bank - 1
```

The boot loader, when the router is started, selects which of the SW banks to download and which configuration profile to use for SW operation.

Default action – list through the banks in sequence and download the first bank in which SW will be with the correct checksum, having used the zero configuration profile.

You can change the loader behavior by specifying directly the number of the bank which should be used to start SW, and the configuration profile number.

When the router SW is updated you have the possibility of verification of the new SW performance without finally transiting to it. To do so, you can start new SW once and if there are any problems (e.g. Hub communication is unavailable), the router will in some time reboot back to the old SW or in any case or if it failed to establish communication with the Hub. This procedure is named fallback. If, when working with the temporary SW, the router is overloaded with user's activities it will also get loaded in the main SW.

To implement this fallback mechanism, you have to specify which bank should be used to download the main SW from and which - the temporary SW.

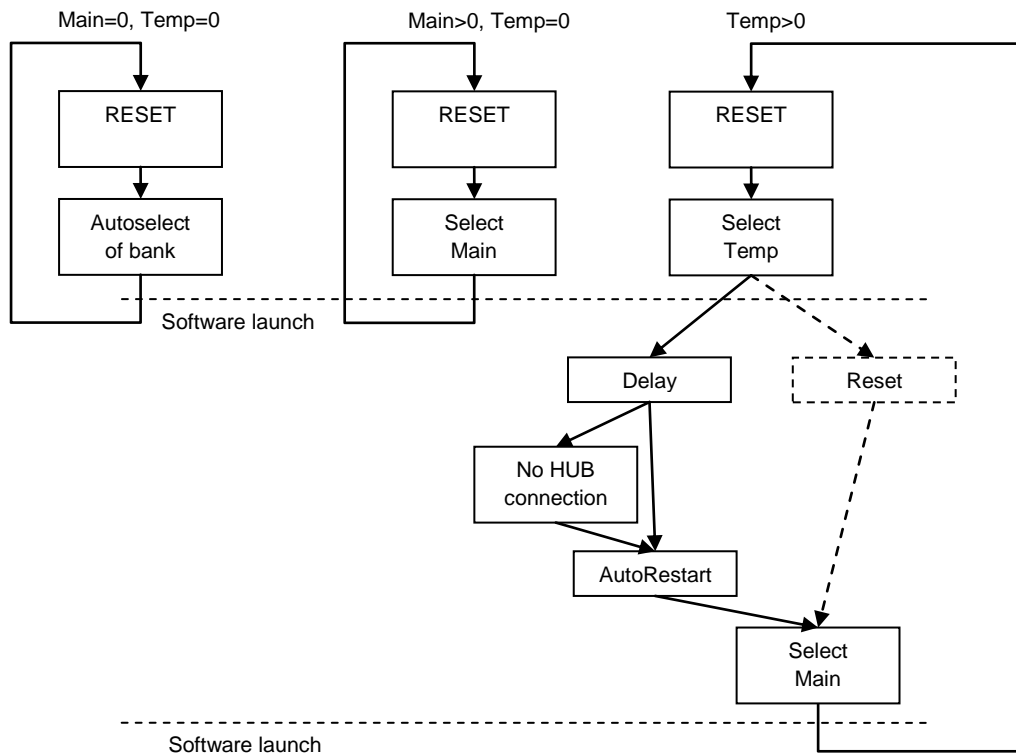

Figure 24 Router reboot procedure

Reboot procedure control commands write the configuration not in the configuration profile but in a separate place. Changes come into force immediately after the command is entered and no save operation is required.

```
boot main 0-3 0-1 - Main boot profile FLASH_BANK(0-auto) CONF_BANK
```

The command selects the main bank for reboot. The first parameter for the bank is SW, the second – for the configuration profile.

```
boot temp 0-3 0-1 - Temp boot profile FLASH_BANK(0-none) CONF_BANK
```

Same for the bank with temporary SW.

```
boot fallback timeout 1-10000 - Temp image auto fallback period (min)
```

Delay in minutes prior to possible reboot back to the main bank.

```
boot fallback reason uptime|link-up - Auto fallback reason
```

After the delay, reboot occurs either in any case or if the station failed to establish communication with Hub.

```
boot fallback stop - Abandon auto fallback
```

Abandons automatic reboot. Manual reboot will in any case take place to the main bank.

Reboot procedure settings can be displayed using «show boot» command:

```
UHP# sh bo
Main:   Flash bank - AUTO      Config profile - 0
Temp:   Flash bank - NONE     Config profile - 0
Fallback delay: 5  Fallback reason: Link-up
```

Example of working with fallback.

- ▶ Old SW in bank 1, new one is written down in bank 3
- ▶ bo ma 1 - main bank 1
- ▶ bo te 3 - temporary bank 3
- ▶ re - reboot (bank 3 will be rebooted)

If you managed to log in the router, issue the "boot fallb stop" command, counting until

reboot will stop.

- ▶ `bo ma 3` - make bank 3 as the main one
- ▶ `bo te 0 0` - switch fallback off

If you failed to log in the router, the router will in 5 minutes (by default) reboot back to bank 1.

If you do not switch fallback off, the router will every time boot from another bank.

3.2.2 Software update

Attention! If SW updating failed or was performed in a wrong way, or contents of all banks was erased, a complicated procedure to restore SW, and even sending the router to the Romantis Service Center may be required.

The updating procedure includes the following steps:

- Downloading new SW to the router using TFTP or X-modem
- Checking the checksum for correctness and proper downloading (version, length)
- Writing the SW to one of the three banks
- Checking the checksum for proper downloading and place of loading (bank)
- Correcting loading parameters (if necessary)
- Rebooting to new SW

SW boot commands:

```
image load tftp IP_ADDR 0-1000 STRING - Load image from TFTP server to RAM buffer
```

Load file from TFTP server to the router buffer memory.

```
image load xmodem - Load image with X-modem to RAM buffer
```

Load using terminal X-modem protocol (not X-modem CRC).

```
image load flash - Copy image from flash to RAM buffer
```

Copy flash bank contents to the buffer memory (a list will be offered). It may be required to rearrange or swap the bank contents.

```
erase flash - Erase flash bank
```

Erases the bank of flash memory.

```
image write - Write image to flash
```

Writes the buffer memory to the flash bank. A menu with the bank selection will be offered. You can cancel the writing procedure at the bank selection step using any letter key.

```
show memory ram|flash|eeprom - Show memory state
```

Using the flash parameter prints out the bank list and bank contents.

4. MAINTENANCE

In many cases, reinstalling system software allows to restore a satellite router functionality (see Section 3.2), which may need reset to the factory default configuration (see Section 4.2).

If the recovery of software cannot be implemented successfully, or if this operation does not eliminate the defect, it is necessary to illuminate the faulty device accordingly to the Section 2.11.4 and replace it by new device.

4.1 Replacement of modules

4.1.1 Common recommendations

Repair of satellite router is carried out by replacing defective units (PSU or a router) or the whole product.

Replacement must be carried out only on original and compatible units, supplied by the manufacturer. After replacing the power supply the router is immediately ready for further operation. In case of a satellite router replacement it has to be reconfigured to the network parameters in accordance with Section 2.2.

4.1.2 Safety instructions

Repair by replacing blocks of satellite router must be carried out by qualified personnel only and with powered off device only.

4.2 Resetting to default settings

To reset user settings you can make use of a special restart procedure. Press RESET button four times with 2 seconds intervals.

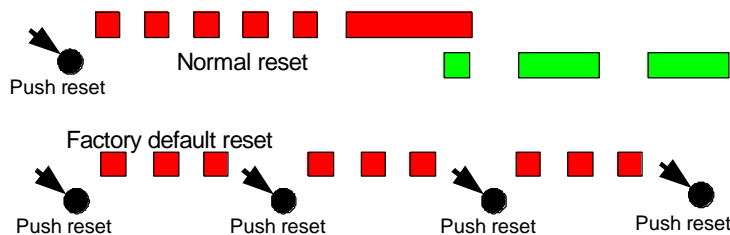

Figure 25 Router resetting to default procedure

Successful reset will be evidenced by fast and simultaneously flashing indicators ERROR and STATUS.

By default, UHP-1000 router is provided with IP-address 192.168.222.222 with mask 255.255.255.248 (/29). Respectively, the computer should be provided with an address, e.g. 192.168.222.217 with the same mask.

The default address is not shown in the route Table. And what is more, it disappears after the first saving of the configuration. Thus the first thing to do, with the Telnet access, is to set a new IP-address (it may be similar to the default address when required), exit the session, and connect to the new address and only then save the configuration.

After the first saving of the configuration the ERROR and STATUS indicators stop flashing simultaneously.

5. STORAGE, TRANSPORTATION AND DISPOSAL

Storage and transportation of satellite routers must be performed in original packaging. Equipment can be stored and transported in pallet with height not more than 10 devices.

Storage and transportation should comply with the following conditions:

- - humidity is not more than $(80 \pm 3)\%$ at a temperature $(25 \pm 2)^\circ\text{C}$;
- - limiting low temperature of storage $(\text{minus } 40 \pm 2)^\circ\text{C}$;
- - limiting high temperature of storage $(50 \pm 2)^\circ\text{C}$.
- - atmospheric pressure $720 \div 770$ mm. Hg.

Utilization of satellite routers must be in accordance with the rules for disposal of industrial or consumer electronics in accordance with applicable law.